

## TTL MSI PARALLEL-IN SERIAL-OUT REGISTERS for application as

- Dual-Source, Parallel-To-Serial Converter

### description

These monolithic shift registers which utilize transistor-transistor logic (TTL) circuits in the familiar Series 54/74 configuration, are composed of four R-S master-slave flip-flops, four AND-OR-INVERT gates, and four inverter-drivers. Internal interconnections of these functions provide a versatile register which performs right-shift operations as a serial-in, serial-out register or as a dual-source, parallel-to-serial converter. A number of these registers may be connected in series to form an n-bit register.

All flip-flops are simultaneously set to a low output level by applying a high-level voltage to the clear input while the internal presets are inactive (high). See the preset function table below. Clearing is independent of the level of the clock input.

The register may be parallel loaded by using the clear input in conjunction with the preset inputs. After clearing all stages to low output levels, data to be loaded is applied to either the P1 or P2 inputs of each register stage (A, B, C, and D) with the corresponding preset enable input, PE1 or PE2, high. Presetting, like clearing, is independent of the level of the clock input.

Transfer of information to the outputs occurs on the positive-going edge of the clock pulse. The proper information must be setup at the R-S inputs of each flip-flop prior to the rising edge of the clock input waveform. The serial input provides this information for the first flip-flop, while the outputs of the subsequent flip-flops provide information for the remaining R-S inputs. The clear input must be at a low level and the internal presets must be inactive (high) when clocking occurs.

**PRESET FUNCTION TABLE  
(BIT A, TYPICAL OF ALL)**

PRESET INPUTS				INTERNAL PRESET A
PE1	P1A	PE2	P2A	
L	X	L	X	H (inactive)
L	X	X	L	H (inactive)
X	L	L	X	H (inactive)
X	L	X	L	H (inactive)
H	H	X	X	L (active)
X	X	H	H	L (active)

- Serial-In Serial-Out Register

SN5494 . . . J OR W PACKAGE  
SN7494 . . . N PACKAGE

(TOP VIEW)

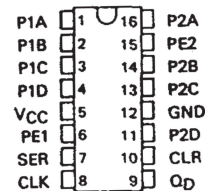

### logic symbol†

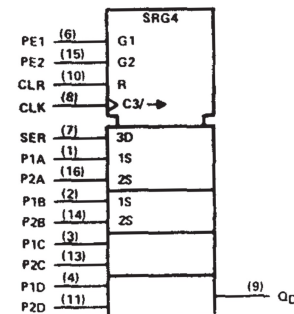

† This symbol is in accordance with ANSI/IEEE Std 91-1984 and IEC Publication 617-12.

**REGISTER FUNCTION TABLE**

INTERNAL PRESETS				INPUTS			INTERNAL OUTPUTS			OUTPUT
A	B	C	D	CLEAR	CLOCK	SERIAL	Q <sub>A</sub>	Q <sub>B</sub>	Q <sub>C</sub>	Q <sub>D</sub>
H	H	H	H	H	X	X	L	L	L	L
L	L	L	L	L	X	X	H	H	H	H
H	H	H	H	L	L	X	Q <sub>A0</sub>	Q <sub>B0</sub>	Q <sub>C0</sub>	Q <sub>D0</sub>
L	H	L	H	L	L	X	H	Q <sub>B0</sub>	H	Q <sub>D0</sub>
H	H	H	H	L	↑	H	H	Q <sub>An</sub>	Q <sub>Bn</sub>	Q <sub>Cn</sub>
H	H	H	H	L	↑	L	L	Q <sub>An</sub>	Q <sub>Bn</sub>	Q <sub>Cn</sub>

H = high level (steady state), L = low level (steady state), X = irrelevant, ↑ = transition from low to high level  
Q<sub>A0</sub>, Q<sub>B0</sub>, Q<sub>C0</sub>, Q<sub>D0</sub> = the level of Q<sub>A</sub>, Q<sub>B</sub>, Q<sub>C</sub>, or Q<sub>D</sub>, respectively, before the indicated steady-state input conditions were established.  
Q<sub>An</sub>, Q<sub>Bn</sub>, Q<sub>Cn</sub> = the level of Q<sub>A</sub>, Q<sub>B</sub>, or Q<sub>C</sub>, respectively, before the most-recent ↑ transition of the clock.

### absolute maximum ratings over operating free-air temperature range (unless otherwise noted)

Supply voltage, V <sub>CC</sub> (see Note 1)	7 V
Input voltage (see Note 2)	5.5 V
Operating free-air temperature range: SN5494 Circuits	-55°C to 125°C
SN7494 Circuits	0°C to 70°C
Storage temperature range	-65°C to 150°C

- NOTES: 1. Voltage values are with respect to network ground terminal.  
2. Input voltage must be zero or positive with respect to network ground terminal.

# SN5494, SN7494 4-BIT SHIFT REGISTERS

SDLS127 – DECEMBER 1972 – REVISED MARCH 1988

## logic diagram (positive logic)

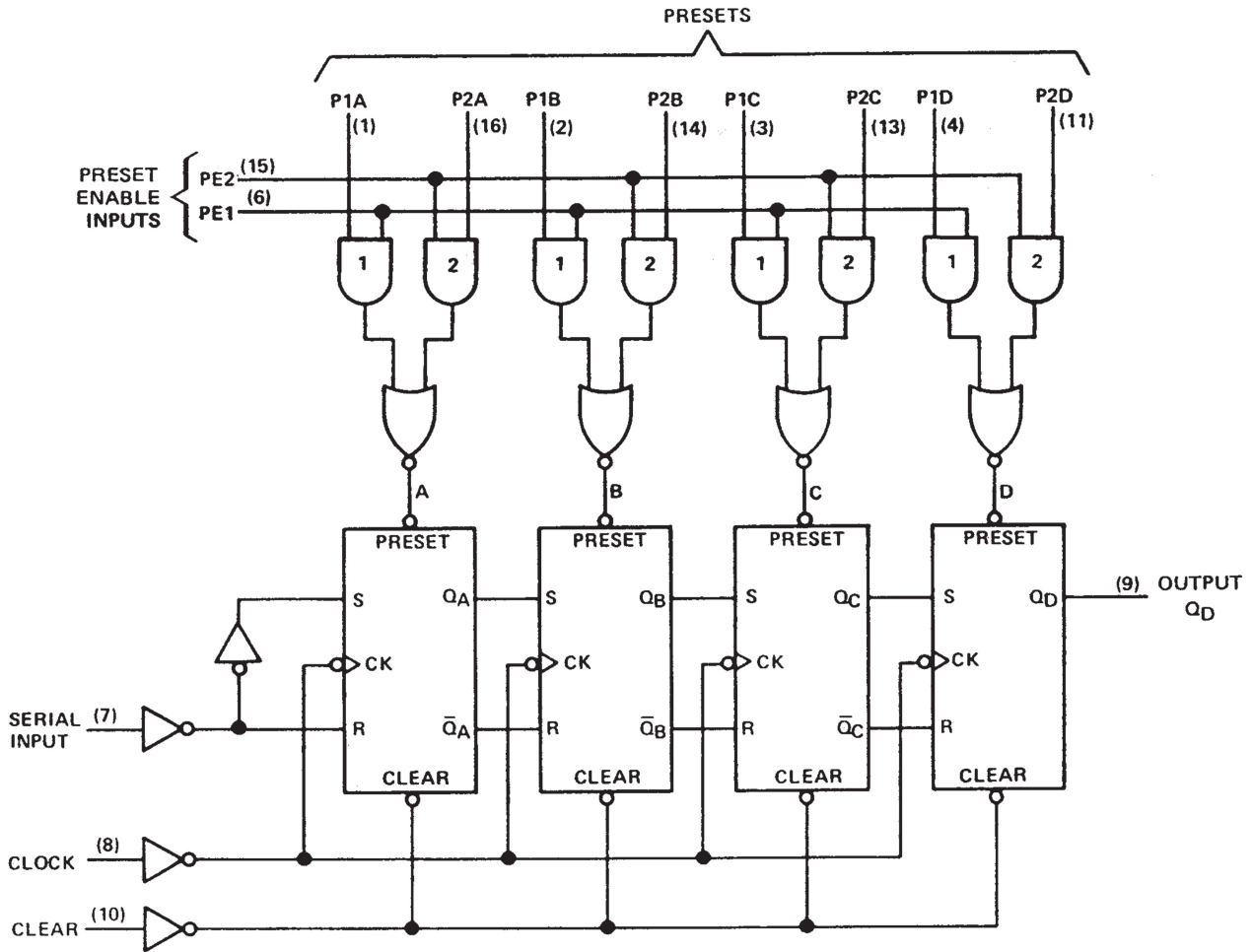

## schematics of inputs and output

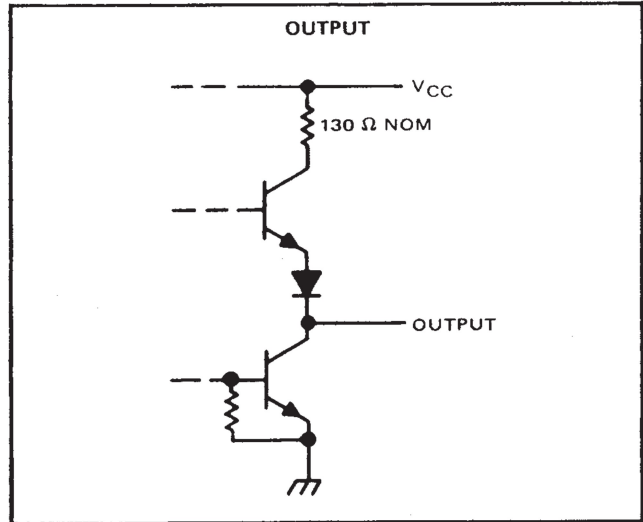
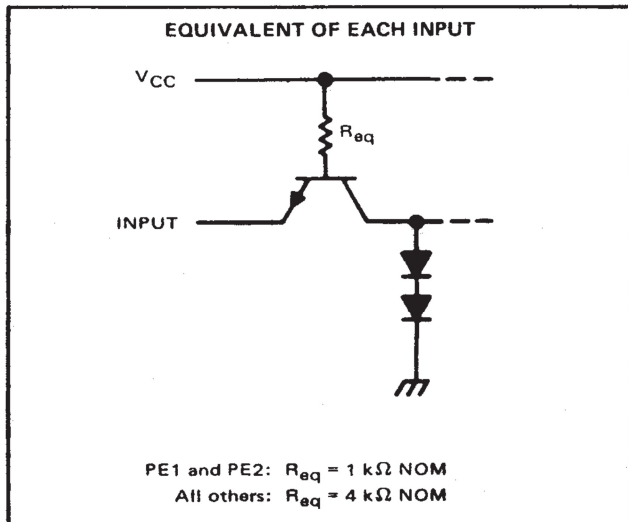

recommended operating conditions

	SN5494			SN7494			UNIT
	MIN	NOM	MAX	MIN	NOM	MAX	
Supply voltage, $V_{CC}$	4.5	5	5.5	4.75	5	5.25	V
High-level output current, $I_{OH}$			-400			-400	$\mu$ A
Low-level output current, $I_{OL}$			16			16	mA
Width of clock pulse, $t_w(\text{clock})$	35			35			ns
Width of clear pulse, $t_w(\text{clear})$	30			30			ns
Width of preset pulse, $t_w(\text{preset})$	30			30			ns
Setup time, $t_{su}$	High-level data			35			ns
	Low-level data			25			
Hold time, $t_h$	0			0			ns
Operating free-air temperature, $T_A$	-55		125	0		70	$^{\circ}$ C

electrical characteristics over recommended operating free-air temperature range (unless otherwise noted)

PARAMETER		TEST CONDITIONS <sup>†</sup>	SN5494			SN7494			UNIT
			MIN	TYP <sup>‡</sup>	MAX	MIN	TYP <sup>‡</sup>	MAX	
$V_{IH}$	High-level input voltage		2			2			V
$V_{IL}$	Low-level input voltage				0.8			0.8	V
$V_{OH}$	High-level output voltage	$V_{CC} = \text{MIN}, V_{IH} = 2 \text{ V}, V_{IL} = 0.8 \text{ V}, I_{OH} = -400 \mu\text{A}$	2.4	3.5		2.4	3.5		V
$V_{OL}$	Low-level output voltage	$V_{CC} = \text{MIN}, V_{IH} = 2 \text{ V}, V_{IL} = 0.8 \text{ V}, I_{OL} = 16 \text{ mA}$		0.2	0.4		0.2	0.4	V
$I_I$	Input current at maximum input voltage	$V_{CC} = \text{MAX}, V_I = 5.5 \text{ V}$			1			1	mA
$I_{IH}$	High-level input current	Presets 1 and 2			160			160	$\mu$ A
		Other inputs	$V_{CC} = \text{MAX}, V_I = 2.4 \text{ V}$		40		40		
$I_{IL}$	Low-level input current	Presets 1 and 2			-6.4			-6.4	mA
		Other inputs	$V_{CC} = \text{MAX}, V_I = 0.4 \text{ V}$		-1.6		-1.6		
$I_{OS}$	Short-circuit output current <sup>§</sup>	$V_{CC} = \text{MAX}$	-20		-57	-18		-57	mA
$I_{CC}$	Supply current	$V_{CC} = \text{MAX},$ See Note 3		35	50		35	58	mA

<sup>†</sup> For conditions shown as MIN or MAX, use the appropriate value specified under recommended operating conditions.

<sup>‡</sup> All typical values are at  $V_{CC} = 5 \text{ V}, T_A = 25^{\circ}\text{C}$ .

<sup>§</sup> Not more than one output should be shorted at a time.

NOTE 3:  $I_{CC}$  is measured with the outputs open, clear grounded following momentary application of 4.5 V, both preset-enable inputs grounded, and all other inputs at 4.5 V.

switching characteristics,  $V_{CC} = 5 \text{ V}, T_A = 25^{\circ}\text{C}$

PARAMETER		TEST CONDITIONS	MIN	TYP	MAX	UNIT
$f_{\text{max}}$	Maximum clock frequency		10			MHz
$t_{\text{PLH}}$	Propagation delay time, low-to-high-level output from clock	$C_L = 15 \text{ pF}, R_L = 400 \Omega,$ See Note 4		25	40	ns
$t_{\text{PHL}}$	Propagation delay time, high-to-low-level output from clock			25	40	ns
$t_{\text{PLH}}$	Propagation delay time, low-to-high level output from preset				35	ns
$t_{\text{PLH}}$	Propagation delay time, high-to-low-level output from clear				40	ns

NOTE 4: Load circuits and voltage waveforms are shown in Section 1.