

SN54S140, SN74S140 DUAL 4-INPUT POSITIVE-NAND 50-OHM LINE DRIVERS

SDLS210 - DECEMBER 1983 - REVISED MARCH 1988

- Package Options Include Ceramic Chip Carriers and Flat Packages in Addition to Plastic and Ceramic DIPs
- Dependable Texas Instruments Quality and Reliability

description

These devices contain two independent 4-input positive-NAND 50-ohm line drivers. They perform the Boolean function $Y = \overline{ABCD}$.

The SN54S140 is characterized for operation over the full military temperature range of -55°C to 125°C . The SN74S140 is characterized for operation from 0°C to 70°C .

logic diagram (each driver)

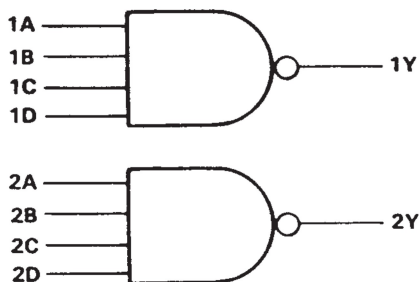

logic symbol†

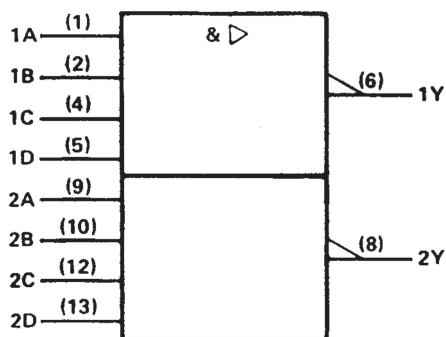

†This symbol is in accordance with ANSI/IEEE Std. 91-1984 and IEC Publication 617-12.

Pin numbers shown are for D, J, N, and W packages.

SN54S140 . . . J OR W PACKAGE SN74S140 . . . D OR N PACKAGE (TOP VIEW)

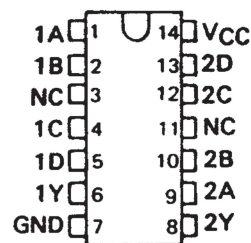

SN54S140 . . . FK PACKAGE (TOP VIEW)

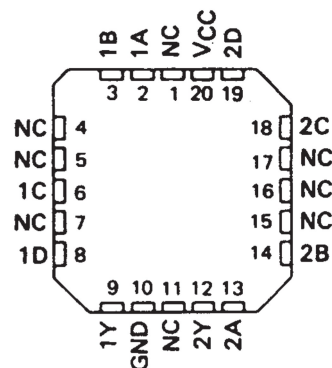

NC—No internal connection

SN54S140, SN74S140

DUAL 4-INPUT POSITIVE-NAND 50-OHM LINE DRIVERS

SDLS210 – DECEMBER 1983 – REVISED MARCH 1988

recommended operating conditions

	SN54S140			SN74S140			UNIT
	MIN	NOM	MAX	MIN	NOM	MAX	
V _{CC} Supply voltage	4.5	5	5.5	4.75	5	5.25	V
V _{IH} High-level input voltage	2			2			V
V _{IL} Low-level input voltage			0.8			0.8	V
I _{OH} High-level output current			-40			-40	mA
I _{OL} Low-level output current			60			60	mA
T _A Operating free-air temperature	-55		125	0		70	°C

electrical characteristics over recommended operating free-air temperature range (unless otherwise noted)

PARAMETER	TEST CONDITIONS†	SN54S140			SN74S140			UNIT
		MIN	TYP‡	MAX	MIN	TYP‡	MAX	
V _{IK}	V _{CC} = MIN, I _I = -18 mA			-1.2			-1.2	V
V _{OH}	V _{CC} = MIN, V _{IL} = 0.8 V, I _{OH} = -3 mA	2.5	3.4		2.7	3.4		V
	V _{CC} = MIN, V _{IL} = 0.5 V, R _O = 50 Ω to GND	2			2			
V _{OL}	V _{CC} = MIN, V _{IH} = 2 V, I _{OL} = 60 mA			0.5			0.5	V
I _I	V _{CC} = MAX, V _I = 5.5 V			1			1	mA
I _{IH}	V _{CC} = MAX, V _{IH} = 2.7 V			0.1			0.1	mA
I _{IL}	V _{CC} = MAX, V _{IL} = 0.5 V			-4			-4	mA
I _{OS} §	V _{CC} = MAX	-50		-225	-50		-225	mA
I _{CCH}	V _{CC} = MAX, V _I = 0 V		10	18		10	18	mA
I _{CCL}	V _{CC} = MAX, V _I = 4.5 V		25	44		25	44	mA

† For conditions shown as MIN or MAX, use the appropriate value specified under recommended operating conditions.

‡ All typical values are at V_{CC} = 5 V, T_A = 25°C.

§ Not more than one output should be shorted at a time, and the duration of the short circuit should not exceed 100 milliseconds.

switching characteristics, V_{CC} = 5 V, T_A = 25°C (see note 2)

PARAMETER	FROM (INPUT)	TO (OUTPUT)	TEST CONDITIONS		MIN	TYP	MAX	UNIT
t _{PLH}	Any	Y	R _L = 93 Ω,	C _L = 50 pF		4	6.5	ns
t _{PHL}						4	6.5	ns
t _{PLH}			R _L = 93 Ω,	C _L = 150 pF		6		ns
t _{PHL}						6		ns

NOTE 2: Load circuits and voltage waveforms are shown in Section 1.