

# SN54LS112A, SN54S112, SN74LS112A, SN74S112A DUAL J-K NEGATIVE-EDGE-TRIGGERED FLIP-FLOPS WITH PRESET AND CLEAR

D2661, APRIL 1982—REVISED MARCH 1988

- Fully Buffered to Offer Maximum Isolation from External Disturbance
- Package Options Include Plastic "Small Outline" Packages, Ceramic Chip Carriers and Flat Packages, and Plastic and Ceramic DIPs
- Dependable Texas Instruments Quality and Reliability

### description

These devices contain two independent J-K negative-edge-triggered flip-flops. A low level at the preset and clear inputs sets or resets the outputs regardless of the levels of the other inputs. When preset and clear are inactive (high), data at the J and K inputs meeting the setup time requirements are transferred to the outputs on the negative-going edge of the clock pulse. Clock triggering occurs at a voltage level and is not directly related to the rise time of the clock pulse. Following the hold time interval, data at the J and K inputs may be changed without affecting the levels at the outputs. These versatile flip-flops can perform as toggle flip-flops by tying J and K high.

The SN54LS112A and SN54S112 are characterized for operation over the full military temperature range of  $-55^{\circ}\text{C}$  to  $125^{\circ}\text{C}$ . The SN74LS112A and SN74S112A are characterized for operation from  $0^{\circ}\text{C}$  to  $70^{\circ}\text{C}$ .

FUNCTION TABLE (each flip-flop)

INPUTS					OUTPUTS	
PRE	CLR	CLK	J	K	Q	$\bar{Q}$
L	H	X	X	X	H	L
H	L	X	X	X	L	H
L	L	X	X	X	H <sup>†</sup>	H <sup>†</sup>
H	H	↓	L	L	Q <sub>0</sub>	$\bar{Q}_0$
H	H	↓	H	L	H	L
H	H	↓	L	H	L	H
H	H	↓	H	H	TOGGLE	
H	H	H	X	X	Q <sub>0</sub>	$\bar{Q}_0$

<sup>†</sup> The output levels in this configuration are not guaranteed to meet the minimum levels for  $V_{OH}$  if the lows at preset and clear are near  $V_{IL}$  minimum. Furthermore, this configuration is nonstable; that is, it will not persist when either preset or clear returns to its inactive (high) level.

SN54LS112A, SN54S112 . . . J OR W PACKAGE  
SN74LS112A, SN74S112A . . . D OR N PACKAGE  
(TOP VIEW)

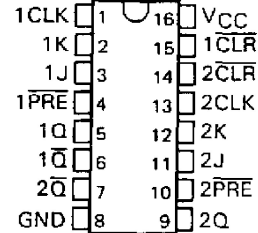

SN54LS112A, SN54S112 . . . FK PACKAGE  
(TOP VIEW)

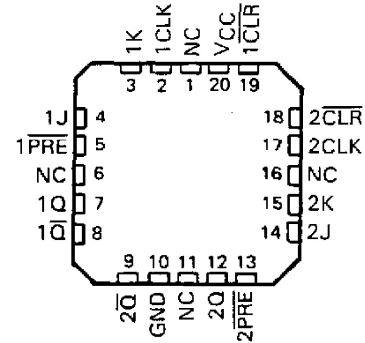

NC—No internal connection

### logic symbol<sup>‡</sup>

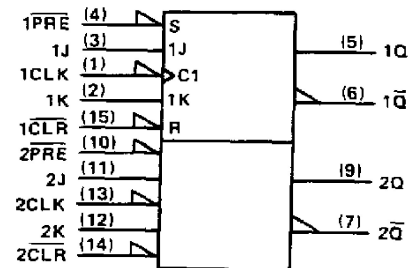

<sup>‡</sup>This symbol is in accordance with ANSI/IEEE Std 91-1984 and IEC Publication 617-12.

Pin numbers shown are for D, J, N, and W packages.

PRODUCTION DATA documents contain information current as of publication date. Products conform to specifications per the terms of Texas Instruments standard warranty. Production processing does not necessarily include testing of all parameters.



POST OFFICE BOX 655012 • DALLAS, TEXAS 75265

Copyright © 1982, Texas Instruments Incorporated

**SN54LS112A, SN54S112, SN74LS112A, SN74S112A**  
**DUAL J-K NEGATIVE-EDGE-TRIGGERED**  
**FLIP-FLOPS WITH PRESET AND CLEAR**

logic diagrams (positive logic)

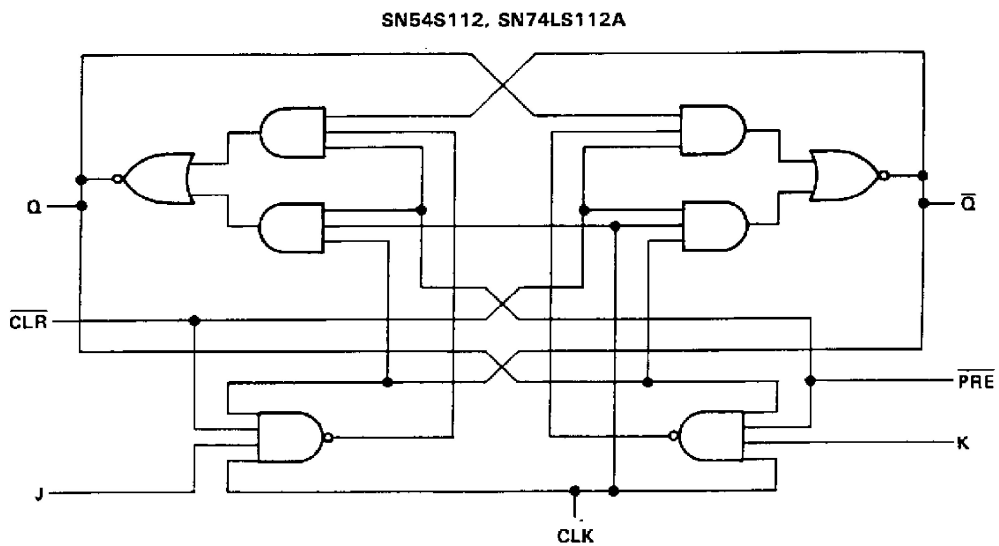
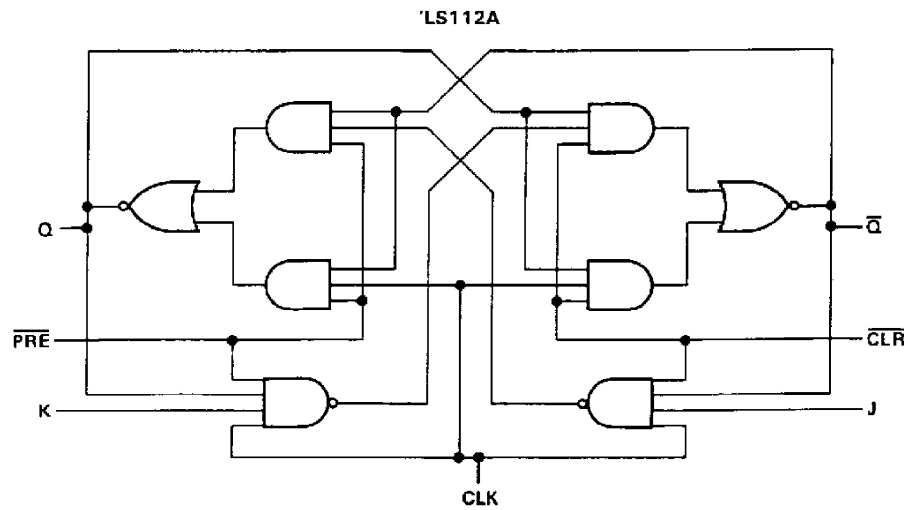

# SN54LS112A, SN54S112, SN74LS112A, SN74S112A DUAL J-K NEGATIVE-EDGE-TRIGGERED FLIP-FLOPS WITH PRESET AND CLEAR

schematics of inputs and outputs

'LS112A

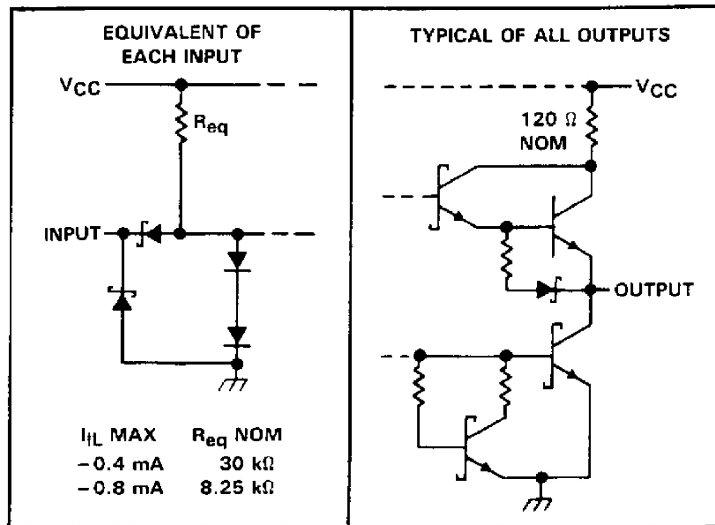

SN54S112, SN74S112A

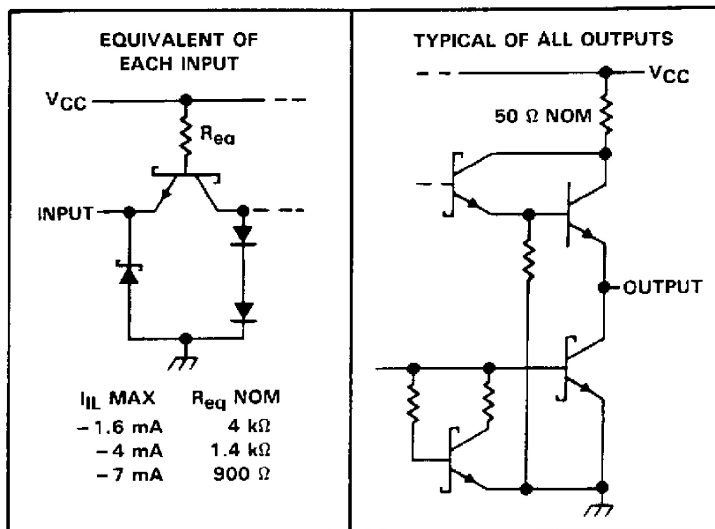

absolute maximum ratings over operating free-air temperature range (unless otherwise noted)

Supply voltage, $V_{CC}$ (see Note 1) .....	7 V
Input voltage: 'LS112A .....	7 V
SN54LS112, SN74LS112A .....	5.5 V
Operating free-air temperature range: SN54' .....	-55°C to 125°C
SN74' .....	0°C to 70°C
Storage temperature range .....	-65°C to 150°C

NOTE 1: Voltage values are with respect to network ground terminal.



POST OFFICE BOX 655012 • DALLAS, TEXAS 75265

# SN54LS112A, SN74LS112A DUAL J-K NEGATIVE-EDGE-TRIGGERED FLIP-FLOPS WITH PRESET AND CLEAR

## recommended operating conditions

		SN54LS112A			SN74LS112A			UNIT
		MIN	NOM	MAX	MIN	NOM	MAX	
$V_{CC}$	Supply voltage	4.5	5	5.5	4.75	5	5.25	V
$V_{IH}$	High-level input voltage	2			2			V
$V_{IL}$	Low-level input voltage			0.7			0.8	V
$I_{OH}$	High-level output current			-0.4			-0.4	mA
$I_{OL}$	Low-level output current			4			8	mA
$f_{clock}$	Clock frequency	0		30	0		30	MHz
$t_w$	Pulse duration	CLK high		20			20	ns
		PRE or CLR low		25			25	
$t_{su}$	Set up time-before CLK↓	Data high or low		20			20	ns
		CLR inactive		25			25	
		PRE inactive		20			20	
$t_h$	Hold time-data after CLK↓	0			0			ns
$T_A$	Operating free-air temperature	-55		125	0		70	°C

## electrical characteristics over recommended operating free-air temperature range (unless otherwise noted)

PARAMETER		TEST CONDITIONS†	SN54LS112A			SN74LS112A			UNIT	
			MIN	TYP‡	MAX	MIN	TYP‡	MAX		
$V_{IK}$		$V_{CC} = \text{MIN}, I_I = -18 \text{ mA}$			-1.5			-1.5	V	
$V_{OH}$		$V_{CC} = \text{MIN}, V_{IH} = 2 \text{ V}, V_{IL} = \text{MAX}, I_{OH} = -0.4 \text{ mA}$	2.5	3.4		2.7	3.4		V	
$V_{OL}$		$V_{CC} = \text{MIN}, V_{IL} = \text{MAX}, V_{IH} = 2 \text{ V}, I_{OL} = 4 \text{ mA}$	0.25	0.4		0.25	0.4		V	
		$V_{CC} = \text{MIN}, V_{IL} = \text{MAX}, V_{IH} = 2 \text{ V}, I_{OL} = 8 \text{ mA}$				0.35	0.5			
$I_I$	J or K	$V_{CC} = \text{MAX}, V_I = 7 \text{ V}$			0.1			0.1	mA	
	CLR or PRE				0.3			0.3		
	CLK				0.4			0.4		
$I_{IH}$	J or K	$V_{CC} = \text{MAX}, V_I = 2.7 \text{ V}$			20			20	μA	
	CLR or PRE				60			60		
	CLK				80			80		
$I_{IL}$	J or K	$V_{CC} = \text{MAX}, V_I = 0.4 \text{ V}$			-0.4			-0.4	mA	
	All other				-0.8			-0.8		
$I_{OS}^{\S}$		$V_{CC} = \text{MAX},$ see Note 2	-20		-100			-20	-100	mA
$I_{CC}$ (Total)		$V_{CC} = \text{MAX},$ see Note 3			4			4		mA

† For conditions shown as MIN or MAX, use the appropriate value specified under recommended operating conditions.

‡ All typical values are at  $V_{CC} = 5 \text{ V}, T_A = 25^\circ\text{C}$ .

§ Not more than one output should be shorted at a time, and the duration of the short-circuit should not exceed one second.

NOTES: 2. For certain devices where state commutation can be caused by shorting an output to ground, an equivalent test may be performed with  $V_O = 2.25 \text{ V}$  and  $2.125 \text{ V}$  for the '54 family and the '74 family, respectively, with the minimum and maximum limits reduced to one half of their stated values.

3. With all outputs open,  $I_{CC}$  is measured with the Q and  $\bar{Q}$  outputs high in turn. At the time of measurement, the clock input is grounded.



**SN54LS112A, SN74LS112A**  
**DUAL J-K NEGATIVE-EDGE-TRIGGERED**  
**FLIP-FLOPS WITH PRESET AND CLEAR**

switching characteristics,  $V_{CC} = 5\text{ V}$ ,  $T_A = 25^\circ\text{C}$  (see Note 4)

PARAMETER	FROM (INPUT)	TO (OUTPUT)	TEST CONDITIONS	MIN	TYP	MAX	UNIT
$f_{\max}$			$R_L = 2\text{ k}\Omega$ , $C_L = 15\text{ pF}$	30	45		MHz
$t_{PLH}$	$\overline{\text{CLR}}$ , $\overline{\text{PRE}}$ or CLK	Q or $\overline{\text{Q}}$			15	20	ns
$t_{PHL}$					15	20	ns

NOTE 4: Load circuits and voltage waveforms are shown in Section 1.

**SN54S112, SN74S112A**  
**DUAL J-K NEGATIVE-EDGE-TRIGGERED**  
**FLIP-FLOPS WITH PRESET AND CLEAR**

**recommended operating conditions**

		SN54S112			SN74S112A			UNIT
		MIN	NOM	MAX	MIN	NOM	MAX	
V <sub>CC</sub>	Supply voltage	4.5	5	5.5	4.75	5	5.25	V
V <sub>IH</sub>	High-level input voltage	2			2			V
V <sub>IL</sub>	Low-level input voltage				0.8			V
I <sub>OH</sub>	High-level output current				-1			mA
I <sub>OL</sub>	Low-level output current				20			mA
t <sub>w</sub>	Pulse duration	CLK high		6	6		ns	
		CLK low		6.5	6.5			
		PRE or CLR low		8	8			
t <sub>su</sub>	Set up time-before CLK↓	Data high or low		7	7		ns	
t <sub>h</sub>	Hold time-data after CLK↓	0			0			ns
T <sub>A</sub>	Operating free-air temperature	-55		125	0		70	°C

**electrical characteristics over recommended operating free-air temperature range (unless otherwise noted)**

PARAMETER		TEST CONDITIONS†	SN54S112			SN74S112A			UNIT
			MIN	TYP‡	MAX	MIN	TYP‡	MAX	
V <sub>IK</sub>		V <sub>CC</sub> = MIN, I <sub>I</sub> = -18 mA	-1.2			-1.2			V
V <sub>OH</sub>		V <sub>CC</sub> = MIN, V <sub>IH</sub> = 2 V, V <sub>IL</sub> = MAX, I <sub>OH</sub> = -1 mA	2.5	3.4		2.7	3.4		V
V <sub>OL</sub>		V <sub>CC</sub> = MIN, V <sub>IH</sub> = 2 V, V <sub>IL</sub> = 0.8 V, I <sub>OL</sub> = 20 mA	0.5			0.5			V
I <sub>I</sub>		V <sub>CC</sub> = MAX, V <sub>I</sub> = 5.5 V	1			1			mA
I <sub>IH</sub>	J or K	V <sub>CC</sub> = MAX, V <sub>I</sub> = 2.7 V	50			50			μA
	All other		100			100			
I <sub>IL</sub>	J or K	V <sub>CC</sub> = MAX, V <sub>I</sub> = 0.5 V	-1.6			-1.6			mA
	CLR <sup>§</sup>		-7			-7			
	PRE <sup>§</sup>		-7			-7			
	CLK		-4			-4			
I <sub>OS</sub> <sup>¶</sup>		V <sub>CC</sub> = MAX	-40	-100		-40	-100	mA	
I <sub>CC</sub> <sup>#</sup>		V <sub>CC</sub> = MAX, see Note 3	15 25		15 25			mA	

† For conditions shown as MIN or MAX, use the appropriate value specified under recommended operating conditions.

‡ All typical values are at V<sub>CC</sub> = 5 V, T<sub>A</sub> = 25°C.

§ Clear is tested with preset high and preset is tested with clear high.

¶ Not more than one output should be shorted at a time, and the duration of the short-circuit should not exceed one second.

# Values are average per flip-flop.

NOTE 3: With all outputs open, I<sub>CC</sub> is measured with the Q and Q̄ outputs high in turn. At the time of measurement, the clock input is grounded.



**SN54S112, SN74S112A**  
**DUAL J-K NEGATIVE-EDGE-TRIGGERED**  
**FLIP-FLOPS WITH PRESET AND CLEAR**

switching characteristics,  $V_{CC} = 5\text{ V}$ ,  $T_A = 25^\circ\text{C}$  (see Note 4)

PARAMETER	FROM (INPUT)	TO (OUTPUT)	TEST CONDITIONS	MIN	TYP	MAX	UNIT
$f_{max}$			$R_L = 280\ \Omega, \quad C_L = 15\ \text{pF}$	80	125		MHz
$t_{PLH}$	$\overline{\text{PRE}}$ or $\overline{\text{CLR}}$	Q or $\overline{Q}$			4	7	ns
$t_{PHL}$	$\overline{\text{PRE}}$ or $\overline{\text{CLR}}$ (CLK high)	$\overline{Q}$ or Q			5	7	ns
	$\overline{\text{PRE}}$ or $\overline{\text{CLR}}$ (CLK low)				5	7	
$t_{PLH}$	CLK	Q or $\overline{Q}$			4	7	ns
$t_{PHL}$					5	7	ns

NOTE 4: Load circuits and voltage waveforms are shown in Section 1.