

SN54LS375, SN74LS375 4-BIT BISTABLE LATCHES

SDLS166 OCTOBER 1976 — REVISED MARCH 1988

- Supply Voltage and Ground on Corner Pins To Simplify P-C Board Layout

description

The SN54LS375 and SN74LS375 bistable latches are electrically and functionally identical to the SN54LS75 and SN74LS75, respectively. Only the arrangement of the terminals has been changed in the SN54LS375 and SN74LS375.

These latches are ideally suited for use as temporary storage for binary information between processing units and input/output or indicator units. Information present at a data (D) input is transferred to the Q output when the enable (C) is high and the Q output will follow the data input as long as the enable remains high. When the enable goes low, the information (that was present at the data input at the time the transition occurred) is retained at the Q output until the enable goes high.

All inputs are diode-clamped to minimize transmission-line effects and simplify system design. The SN54LS375 is characterized for operation over the full military temperature range of -55°C to 125°C; SN74LS375 is characterized for operation from 0°C to 70°C.

FUNCTION TABLE
(EACH LATCH)

INPUTS		OUTPUTS	
D	G	Q	\bar{Q}
L	H	L	H
H	H	H	L
X	L	Q_0	\bar{Q}_0

H = high level; L = low level; X = irrelevant
 Q_0 = the level of Q before the high-to-low transition of C.

logic symbol†

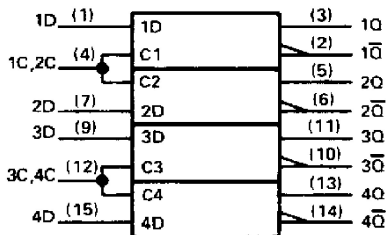

† This symbol is in accordance with ANSI/IEEE Std. 91-1984 and IEC Publication 617-12.
Pin numbers shown are for D, J, N, and W packages.

SN54LS375 . . . J OR W PACKAGE SN74LS375 . . . D OR N PACKAGE

(TOP VIEW)

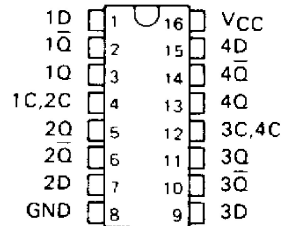

SN54LS375 . . . FK PACKAGE

(TOP VIEW)

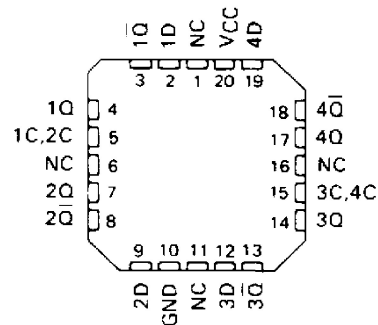

NC - No internal connection

logic diagram (each latch)

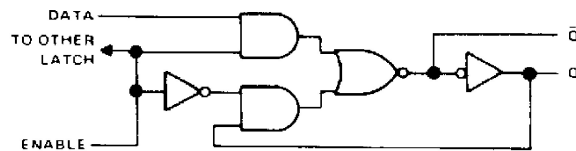

schematics of inputs and outputs

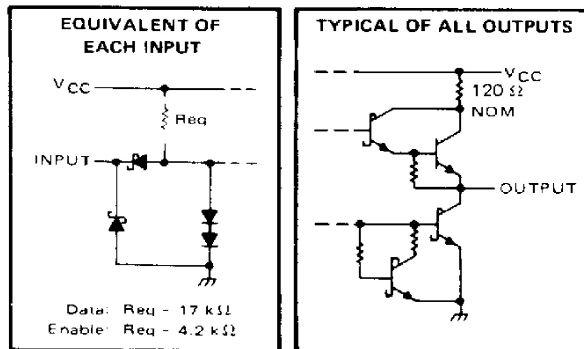

PRODUCTION DATA documents contain information current as of publication date. Products conform to specifications per the terms of Texas Instruments standard warranty. Production processing does not necessarily include testing of all parameters.

TEXAS
INSTRUMENTS

POST OFFICE BOX 655012 • DALLAS, TEXAS 75265

SN54LS375, SN74LS375

4-BIT BISTABLE LATCHES

absolute maximum ratings over operating free-air temperature range (unless otherwise noted)

Supply voltage, V_{CC} (see Note 1)	7 V
Input voltage	7 V
Operating free-air temperature range: SN54LS375	-55°C to 125°C
SN74LS375	0°C to 70°C
Storage temperature range	-65°C to 150°C

NOTE 1: Voltage values are with respect to network ground terminal.

recommended operating conditions

		SN54LS375			SN74LS375			UNIT		
		MIN	NOM	MAX	MIN	NOM	MAX			
V_{CC}	Supply voltage	4.5	5	5.5	4.75	5	5.25	V		
V_{IH}	High-level input voltage	2			2			V		
V_{IL}	Low-level input voltage	0.7			0.8			V		
I_{OH}	High-level output current	-0.4			-0.4			mA		
I_{OL}	Low-level output current	4			8			mA		
t_w	Width of enabling pulse	20			20			ns		
t_{setup}	Setup time	20			20			ns		
t_{hold}	Hold time	0			0			ns		
T_A	Operating free-air temperature	-55			125			0	70	°C

electrical characteristics over recommended operating free-air temperature range (unless otherwise noted)

PARAMETER	TEST CONDITIONS †	SN54LS375			SN74LS375			UNIT
		MIN	TYP ‡	MAX	MIN	TYP ‡	MAX	
V_{IK}	$V_{CC} = \text{MIN.}$, $I_I = -18 \text{ mA}$	-1.5			-1.5			V
V_{OH}	$V_{CC} = \text{MIN.}$, $V_{IH} = 2 \text{ V}$, $V_{IL} = \text{MAX}$ $I_{OH} = -0.4 \text{ mA}$	2.5	3.5		2.7	3.5		V
V_{OL}	$V_{CC} = \text{MIN.}$, $V_{IH} = 2 \text{ V}$, $V_{IL} = \text{MAX}$	$I_{OL} = 4 \text{ mA}$		0.25		0.25		V
		$I_{OL} = 8 \text{ mA}$		0.35		0.5		
I_I	$V_{CC} = \text{MAX.}$, $V_I = 7 \text{ V}$	D input		0.1		0.1		mA
		C input		0.4		0.4		
I_{IH}	$V_{CC} = \text{MAX.}$, $V_I = 2.7 \text{ V}$	D input		20		20		μA
		C input		80		80		
I_{IL}	$V_{CC} = \text{MAX.}$, $V_I = 0.4 \text{ V}$	D input		-0.4		-0.4		mA
		C input		-1.6		-1.6		
$I_{OS} \ddagger$	$V_{CC} = \text{MAX.}$	-20		-100	-20		-100	mA
I_{CC}	$V_{CC} = \text{MAX.}$, See Note 2	6.3		12	6.3		12	mA

† For conditions shown as MIN or MAX, use the appropriate value specified under recommended operating conditions.

‡ All typical values are at $V_{CC} = 5 \text{ V}$, $T_A = 25^\circ\text{C}$.

§ Not more than one output should be shorted at a time.

NOTE 2: I_{CC} is tested with all inputs grounded and all outputs open.

switching characteristics, $V_{CC} = 5 \text{ V}$, $T_A = 25^\circ\text{C}$ (see note 3)

PARAMETER	FROM (INPUT)	TO (OUTPUT)	TEST CONDITIONS	MIN	TYP	MAX	UNIT
t_{PLH}	D	O	$R_L = 2 \text{ k}\Omega$, $C_L = 15 \text{ pF}$	15	27	ns	
t_{PHL}				9	17		
t_{PLH}	D	\bar{O}		12	20	ns	
t_{PHL}				7	15		
t_{PLH}	C	O		15	27	ns	
t_{PHL}				14	25		
t_{PLH}	C	\bar{O}		16	30	ns	
t_{PHL}				7	15		

NOTE 3: Load circuits and voltage waveforms are shown in Section 1.