

74AC299, 74ACT299

8-Input Universal Shift/Storage Register with Common Parallel I/O Pins

Features

- I_{CC} and I_{OZ} reduced by 50%
- Common parallel I/O for reduced pin count
- Additional serial inputs and outputs for expansion
- Four operating modes: shift left, shift right, load and store
- 3-STATE outputs for bus-oriented applications
- Outputs source/sink 24mA
- ACT299 has TTL-compatible inputs

General Description

The AC/ACT299 is an 8-bit universal shift/storage register with 3-STATE outputs. Four modes of operation are possible: hold (store), shift left, shift right and load data. The parallel load inputs and flip-flop outputs are multiplexed to reduce the total number of package pins. Additional outputs are provided for flip-flops Q_0 , Q_7 to allow easy serial cascading. A separate active LOW Master Reset is used to reset the register.

Ordering Information

Order Number	Package Number	Package Description
74AC299SC	M20B	20-Lead Small Outline Integrated Circuit (SOIC), JEDEC MS-013, 0.300" Wide
74AC299SJ	M20D	20-Lead Small Outline Package (SOP), EIAJ TYPE II, 5.3mm Wide
74AC299MTC	MTC20	20-Lead Thin Shrink Small Outline Package (TSSOP), JEDEC MO-153, 4.4mm Wide
74AC299PC	N20A	20-Lead Plastic Dual-In-Line Package (PDIP), JEDEC MS-001, 0.300" Wide
74ACT299SC	M20B	20-Lead Small Outline Integrated Circuit (SOIC), JEDEC MS-013, 0.300" Wide
74ACT299MTC	MTC20	20-Lead Thin Shrink Small Outline Package (TSSOP), JEDEC MO-153, 4.4mm Wide
74ACT299PC	N20A	20-Lead Plastic Dual-In-Line Package (PDIP), JEDEC MS-001, 0.300" Wide

Device also available in Tape and Reel. Specify by appending suffix letter "X" to the ordering number.

 All packages are lead free per JEDEC: J-STD-020B standard.

Connection Diagram

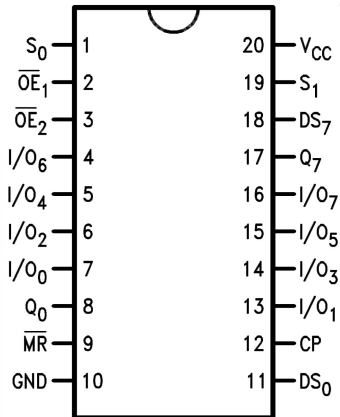

Pin Description

Pin Names	Description
CP	Clock Pulse Input
DS ₀	Serial Data Input for Right Shift
DS ₇	Serial Data Input for Left Shift
S ₀ , S ₁	Mode Select Inputs
MR	Asynchronous Master Reset
OE ₁ , OE ₂	3-STATE Output Enable Inputs
I/O ₀ –I/O ₇	Parallel Data Inputs or 3-STATE Parallel Outputs
Q ₀ , Q ₇	Serial Outputs

Functional Description

The AC/ACT299 contains eight edge-triggered D-type flip-flops and the interstage logic necessary to perform synchronous shift left, shift right, parallel load and hold operations. The type of operation is determined by S₀ and S₁, as shown in the Truth Table. All flip-flop outputs are brought out through 3-STATE buffers to separate I/O pins that also serve as data inputs in the parallel load mode. Q₀ and Q₇ are also brought out on other pins for expansion in serial shifting of longer words.

A LOW signal on MR overrides the Select and CP inputs and resets the flip-flops. All other state changes are initiated by the rising edge of the clock. Inputs can change when the clock is in either state provided only that the recommended setup and hold times, relative to the rising edge of CP, are observed.

A HIGH signal on either OE₁ or OE₂ disables the 3-STATE buffers and puts the I/O pins in the high impedance state. In this condition the shift, hold, load and reset operations can still occur. The 3-STATE buffers are also disabled by HIGH signals on both S₀ and S₁ in preparation for a parallel load operation.

Logic Symbols

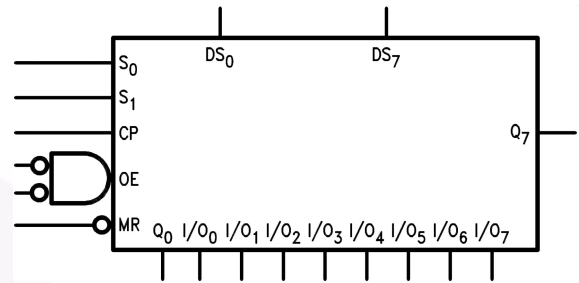

IEEE/IEC

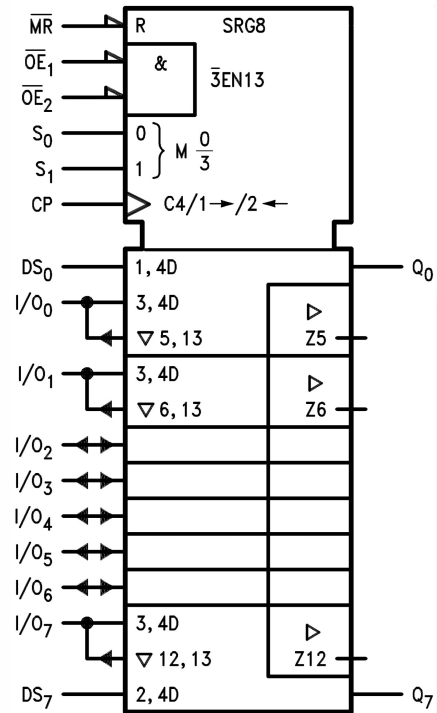

Truth Table

Inputs				Response
MR	S ₁	S ₀	CP	
L	X	X	X	Asynchronous Reset; Q ₀ –Q ₇ = LOW
H	H	H	↗	Parallel Load; I/O _n → Q _n
H	L	H	↗	Shift Right; DS ₀ → Q ₀ , Q ₀ → Q ₁ , etc.
H	H	L	↗	Shift Left, DS ₇ → Q ₇ , Q ₇ → Q ₆ , etc.
H	L	L	X	Hold

H = HIGH Voltage Level

L = LOW Voltage Level

X = Immaterial

↗ = LOW-to-HIGH Transition

Logic Diagram

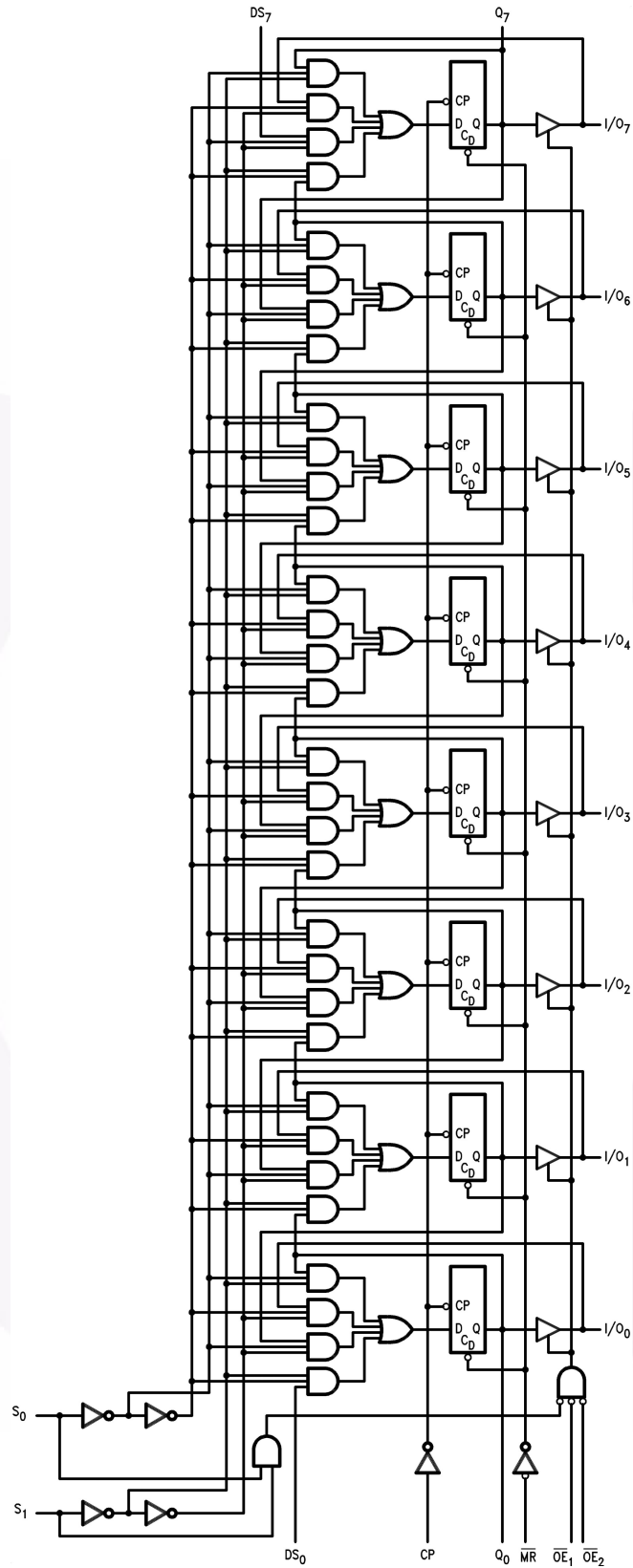

Please note that this diagram is provided only for the understanding of logic operations and should not be used to estimate propagation delays.

Absolute Maximum Ratings

Stresses exceeding the absolute maximum ratings may damage the device. The device may not function or be operable above the recommended operating conditions and stressing the parts to these levels is not recommended. In addition, extended exposure to stresses above the recommended operating conditions may affect device reliability. The absolute maximum ratings are stress ratings only.

Symbol	Parameter	Rating
V_{CC}	Supply Voltage	-0.5V to +7.0V
I_{IK}	DC Input Diode Current $V_I = -0.5V$	-20mA
	$V_I = V_{CC} + 0.5$	+20mA
V_I	DC Input Voltage	-0.5V to $V_{CC} + 0.5V$
I_{OK}	DC Output Diode Current $V_O = -0.5V$	-20mA
	$V_O = V_{CC} + 0.5V$	+20mA
V_O	DC Output Voltage	-0.5V to $V_{CC} + 0.5V$
I_O	DC Output Source or Sink Current	$\pm 50mA$
I_{CC} or I_{GND}	DC V_{CC} or Ground Current per Output Pin	$\pm 50mA$
T_{STG}	Storage Temperature	-65°C to +150°C
T_J	Junction Temperature	140°C

Recommended Operating Conditions

The Recommended Operating Conditions table defines the conditions for actual device operation. Recommended operating conditions are specified to ensure optimal performance to the datasheet specifications. Fairchild does not recommend exceeding them or designing to absolute maximum ratings.

Symbol	Parameter	Rating
V_{CC}	Supply Voltage (unless otherwise specified) AC	2.0V to 6.0V
	ACT	4.5V to 5.5V
V_I	Input Voltage	0V to V_{CC}
V_O	Output Voltage	0V to V_{CC}
T_A	Operating Temperature	-40°C to +85°C
$\Delta V / \Delta t$	Minimum Input Edge Rate, AC Devices: V_{IN} from 30% to 70% of V_{CC} , V_{CC} @ 3.3V, 4.5V, 5.5V	125mV/ns
$\Delta V / \Delta t$	Minimum Input Edge Rate, ACT Devices: V_{IN} from 0.8V to 2.0V, V_{CC} @ 4.5V, 5.5V	125mV/ns

DC Electrical Characteristics for AC

Symbol	Parameter	V _{CC} (V)	Conditions	T _A = +25°C		T _A = -40°C to +85°C		Units	
				Typ.	Guaranteed Limits				
V _{IH}	Minimum HIGH Level Input Voltage	3.0	V _{OUT} = 0.1V or V _{CC} - 0.1V	1.5	2.1	2.1		V	
		4.5		2.25	3.15	3.15			
		5.5		2.75	3.85	3.85			
V _{IL}	Maximum LOW Level Input Voltage	3.0	V _{OUT} = 0.1V or V _{CC} - 0.1V	1.5	0.9	0.9		V	
		4.5		2.25	1.35	1.35			
		5.5		2.75	1.65	1.65			
V _{OH}	Minimum HIGH Level Output Voltage	3.0	I _{OUT} = -50μA	2.99	2.9	2.9		V	
		4.5		4.49	4.4	4.4			
		5.5		5.49	5.4	5.4			
		3.0	V _{IN} = V _{IL} or V _{IH} , I _{OH} = -12mA		2.56	2.46			
		4.5		V _{IN} = V _{IL} or V _{IH} , I _{OH} = -24mA		3.86	3.76		
		5.5			V _{IN} = V _{IL} or V _{IH} , I _{OH} = -24mA ⁽¹⁾		4.86		4.76
V _{OL}	Maximum LOW Level Output Voltage	3.0	I _{OUT} = 50μA	0.002		0.1	0.1		V
		4.5		0.001	0.1	0.1			
		5.5		0.001	0.1	0.1			
		3.0	V _{IN} = V _{IL} or V _{IH} , I _{OL} = 12mA		0.36	0.44			
		4.5		V _{IN} = V _{IL} or V _{IH} , I _{OL} = 24mA		0.36	0.44		
		5.5			V _{IN} = V _{IL} or V _{IH} , I _{OL} = 24mA ⁽¹⁾		0.36	0.44	
I _{IN} ⁽²⁾	Maximum Input Leakage Current	5.5	V _I = V _{CC} , GND			±0.1	±1.0	μA	
I _{OLD}	Minimum Dynamic Output Current ⁽³⁾	5.5	V _{OLD} = 1.65V Max.			75		mA	
I _{OHD}		5.5	V _{OHD} = 3.85V Min.			-75		mA	
I _{CC} ⁽²⁾	Maximum Quiescent Supply Current	5.5	V _{IN} = V _{CC} or GND		4.0	40.0		μA	
I _{OZT}	Maximum I/O Leakage Current	5.5	V _I (OE) = V _{IL} , V _{IH} ; V _I = V _{CC} , GND; V _O = V _{CC} , GND		±0.3	±3.0		μA	

Notes:

- All outputs loaded; thresholds on input associated with output under test.
- I_{IN} and I_{CC} @ 3.0V are guaranteed to be less than or equal to the respective limit @ 5.5V V_{CC}.
- Maximum test duration 2.0ms, one output loaded at a time.

DC Electrical Characteristics for ACT

Symbol	Parameter	V _{CC} (V)	Conditions	T _A = +25°C		T _A = -40°C to +85°C		Units
				Typ.	Guaranteed Limits			
V _{IH}	Minimum HIGH Level Input Voltage	4.5	V _{OUT} = 0.1V or V _{CC} - 0.1V	1.5	2.0	2.0		V
		5.5		1.5	2.0	2.0		
V _{IL}	Maximum LOW Level Input Voltage	4.5	V _{OUT} = 0.1V or V _{CC} - 0.1V	1.5	0.8	0.8		V
		5.5		1.5	0.8	0.8		
V _{OH}	Minimum HIGH Level Output Voltage	4.5	I _{OUT} = -50μA	4.49	4.4	4.4		V
		5.5		5.49	5.4	5.4		
		4.5	V _{IN} = V _{IL} or V _{IH} , I _{OH} = -24mA	0.0001	3.86	3.76		
		5.5		V _{IN} = V _{IL} or V _{IH} , I _{OH} = -24mA ⁽⁴⁾		4.86	4.76	
V _{OL}	Maximum LOW Level Output Voltage	4.5	I _{OUT} = 50μA	0.001	0.1	0.1		V
		5.5		0.001	0.1	0.1		
		4.5	V _{IN} = V _{IL} or V _{IH} , I _{OL} = 24mA		0.36	0.44		
		5.5		V _{IN} = V _{IL} or V _{IH} , I _{OL} = 24mA ⁽⁴⁾		0.36	0.44	
I _{IN}	Maximum Input Leakage Current	5.5	V _I = V _{CC} , GND		±0.1	±1.0		μA
I _{CCT}	Maximum I _{CC} /Input	5.5	V _I = V _{CC} - 2.1V	0.6		1.5		mA
I _{OLD}	Minimum Dynamic Output Current ⁽⁵⁾	5.5	V _{OLD} = 1.65V Max.			75		mA
I _{OHD}		5.5	V _{OHD} = 3.85V Min.			-75		mA
I _{CC}	Maximum Quiescent Supply Current	5.5	V _{IN} = V _{CC} or GND		4.0	40.0		μA
I _{OZT}	Maximum I/O Leakage Current	5.5	V _I (OE) = V _{IL} , V _{IH} ; V _I = V _{CC} , GND; V _O = V _{CC} , GND		±0.3	±3.0		μA

Notes:

- All outputs loaded; thresholds on input associated with output under test.
- Maximum test duration 2.0ms, one output loaded at a time.

AC Electrical Characteristics for AC

Symbol	Parameter	V _{CC} (V) ⁽⁶⁾	T _A = +25°C, C _L = 50pF			T _A = -40°C to +85°C, C _L = 50pF		Units
			Min.	Typ.	Max.	Min.	Max.	
f _{MAX}	Maximum Input Frequency	3.3	90	124		80		MHz
		5.0	130	173		105		
t _{PLH}	Propagation Delay, CP to Q ₀ or Q ₇ (Shift Left or Right)	3.3	8.5	14.0	20.5	7.0	22.0	ns
		5.0	5.5	9.5	14.0	4.5	15.0	
t _{PHL}	Propagation Delay, CP to Q ₀ or Q ₇ (Shift Left or Right)	3.3	8.5	14.5	21.5	7.0	23.0	ns
		5.0	5.5	10.0	14.5	5.0	16.0	
t _{PLH}	Propagation Delay, \overline{CP} to I/O _n	3.3	9.0	14.5	20.5	7.5	22.5	ns
		5.0	6.0	10.0	14.5	5.0	16.0	
t _{PHL}	Propagation Delay, \overline{CP} to I/O _n	3.3	10.0	16.0	23.0	8.5	24.5	ns
		5.0	6.5	11.0	16.0	6.0	17.5	
t _{PHL}	Propagation Delay, \overline{MR} to Q ₀ or Q ₇	3.3	9.0	15.5	22.5	7.5	25.0	ns
		5.0	5.5	10.5	15.5	5.0	17.0	
t _{PHL}	Propagation Delay, \overline{MR} to I/O _n	3.3	9.0	15.0	21.5	7.5	24.0	ns
		5.0	5.5	10.0	15.0	5.0	16.5	
t _{PZH}	Output Enable Time, \overline{OE} to I/O _n	3.3	7.0	12.0	18.0	6.0	19.5	ns
		5.0	4.5	8.5	12.5	4.0	13.5	
t _{PZL}	Output Enable Time, \overline{OE} to I/O _n	3.3	7.0	12.5	18.0	6.0	20.5	ns
		5.0	5.0	8.0	12.5	4.0	14.0	
t _{PHZ}	Output Disable Time, \overline{OE} to I/O _n	3.3	6.5	13.0	18.5	5.5	19.5	ns
		5.0	3.5	9.5	14.0	3.0	15.0	
t _{PLZ}	Output Disable Time, \overline{OE} to I/O _n	3.3	5.5	11.5	17.0	4.5	19.0	ns
		5.0	3.5	8.0	12.5	2.0	13.5	

Note:

6. Voltage range 3.3 is 3.3V ± 0.3V. Voltage range 5.0 is 5.0V ± 0.5V.

AC Operating Requirements for AC

Symbol	Parameter	V _{CC} (V) ⁽⁷⁾	T _A = +25°C, C _L = 50pF		T _A = -40°C to +85°C, C _L = 50pF		Units
			Typ.	Guaranteed Minimum			
t _S	Setup Time, HIGH or LOW, S ₀ or S ₁ to CP	3.3	3.0	8.0	8.5	ns	
		5.0	2.0	5.0	5.5		
t _H	Hold Time, HIGH or LOW, S ₀ or S ₁ to CP	3.3	-3.0	0.5	0.5	ns	
		5.0	-1.5	1.0	1.0		
t _S	Setup Time, HIGH or LOW, I/O _n to CP	3.3	2.0	5.5	6.0	ns	
		5.0	1.0	3.5	4.0		
t _H	Hold Time, HIGH or LOW, I/O _n to CP	3.3	-2.0	0	0	ns	
		5.0	-1.0	1.0	1.0		
t _S	Setup Time, HIGH or LOW, DS ₀ or DS ₇ to CP	3.3	2.5	6.5	7.0	ns	
		5.0	1.5	4.0	4.5		
t _H	Hold Time, HIGH or LOW, DS ₀ or DS ₇ to CP	3.3	-2.0	0	0.5	ns	
		5.0	-1.0	1.0	1.0		
t _W	CP Pulse Width, LOW	3.3	3.5	4.5	5.0	ns	
		5.0	2.0	3.5	3.5		
t _W	$\overline{\text{MR}}$ Pulse Width, LOW	3.3	4.0	4.5	5.0	ns	
		5.0	2.0	3.5	3.5		
t _{REC}	Recovery Time, $\overline{\text{MR}}$ to CP	3.3	0	1.5	1.5	ns	
		5.0	0.5	1.5	1.5		

Note:

7. Voltage range 3.3 is 3.3V ± 0.3V. Voltage range 5.0 is 5.0V ± 0.5V.

AC Electrical Characteristics for ACT

Symbol	Parameter	V_{CC} (V) ⁽⁸⁾	$T_A = +25^\circ\text{C}$, $C_L = 50\text{pF}$			$T_A = -40^\circ\text{C to } +85^\circ\text{C}$, $C_L = 50\text{pF}$		Units
			Min.	Typ.	Max.	Min.	Max.	
f_{MAX}	Maximum Input Frequency	5.0	120	170		110		MHz
t_{PLH}	Propagation Delay, CP to Q_0 or Q_7 (Shift Left or Right)	5.0	4.0	8.5	12.5	3.0	14.0	ns
t_{PHL}	Propagation Delay, CP to Q_0 or Q_7 (Shift Left or Right)	5.0	4.0	9.0	13.5	3.5	15.0	ns
t_{PLH}	Propagation Delay, CP to I/O_n	5.0	4.5	8.5	12.5	4.5	13.5	ns
t_{PHL}	Propagation Delay, CP to I/O_n	5.0	5.0	9.5	15.0	4.5	16.5	ns
t_{PHL}	Propagation Delay, \overline{MR} to Q_0 or Q_7	5.0	4.0	14.0	15.0	4.0	18.0	ns
t_{PHL}	Propagation Delay, \overline{MR} to I/O_n	5.0	4.0	13.0	14.5	3.5	17.5	ns
t_{PZH}	Output Enable Time, \overline{OE} to I/O_n	5.0	2.5	8.0	12.0	1.5	13.0	ns
t_{PZL}	Output Enable Time, \overline{OE} to I/O_n	5.0	2.0	8.0	12.0	1.5	13.5	ns
t_{PHZ}	Output Disable Time, \overline{OE} to I/O_n	5.0	2.0	8.5	12.5	2.0	13.5	ns
t_{PLZ}	Output Disable Time, \overline{OE} to I/O_n	5.0	2.5	8.0	11.5	2.0	12.5	ns

Note

8. Voltage range 5.0 is $5.0\text{V} \pm 0.5\text{V}$.

AC Operating Requirements for ACT

Symbol	Parameter	V_{CC} (V) ⁽⁹⁾	$T_A = +25^\circ\text{C}$, $C_L = 50\text{pF}$		$T_A = -40^\circ\text{C to } +85^\circ\text{C}$, $C_L = 50\text{pF}$		Units
			Typ.	Guaranteed Minimum			
t_S	Setup Time, HIGH or LOW, S_0 or S_1 to CP	5.0	2.0	5.0	5.5		ns
t_H	Hold Time, HIGH or LOW, S_0 or S_1 to CP	5.0	-2.0	1.0	1.0		ns
t_S	Setup Time, HIGH or LOW, I/O_n to CP	5.0	1.5	4.0	4.5		ns
t_H	Hold Time, HIGH or LOW, I/O_n to CP	5.0	-1.0	1.0	1.0		ns
t_S	Setup Time, HIGH or LOW, DS_0 or DS_7 to CP	5.0	1.5	4.5	5.0		ns
t_H	Hold Time, HIGH or LOW, DS_0 or DS_7 to CP	5.0	-1.0	1.0	1.0		ns
t_W	CP Pulse Width, HIGH or LOW	5.0	2.0	4.0	4.5		ns
t_W	\overline{MR} Pulse Width, LOW	5.0	2.0	3.5	3.5		ns
t_{REC}	Recovery Time, \overline{MR} to CP	5.0	0	1.5	1.5		ns

Note

9. Voltage range 5.0 is $5.0\text{V} \pm 0.5\text{V}$.

Capacitance

Symbol	Parameter	Conditions	Typ.	Units
C_{IN}	Input Capacitance	$V_{CC} = 5.0\text{V}$	4.5	pF
C_{PD}	Power Dissipation Capacitance	$V_{CC} = 5.5\text{V}$	170	pF

Physical Dimensions

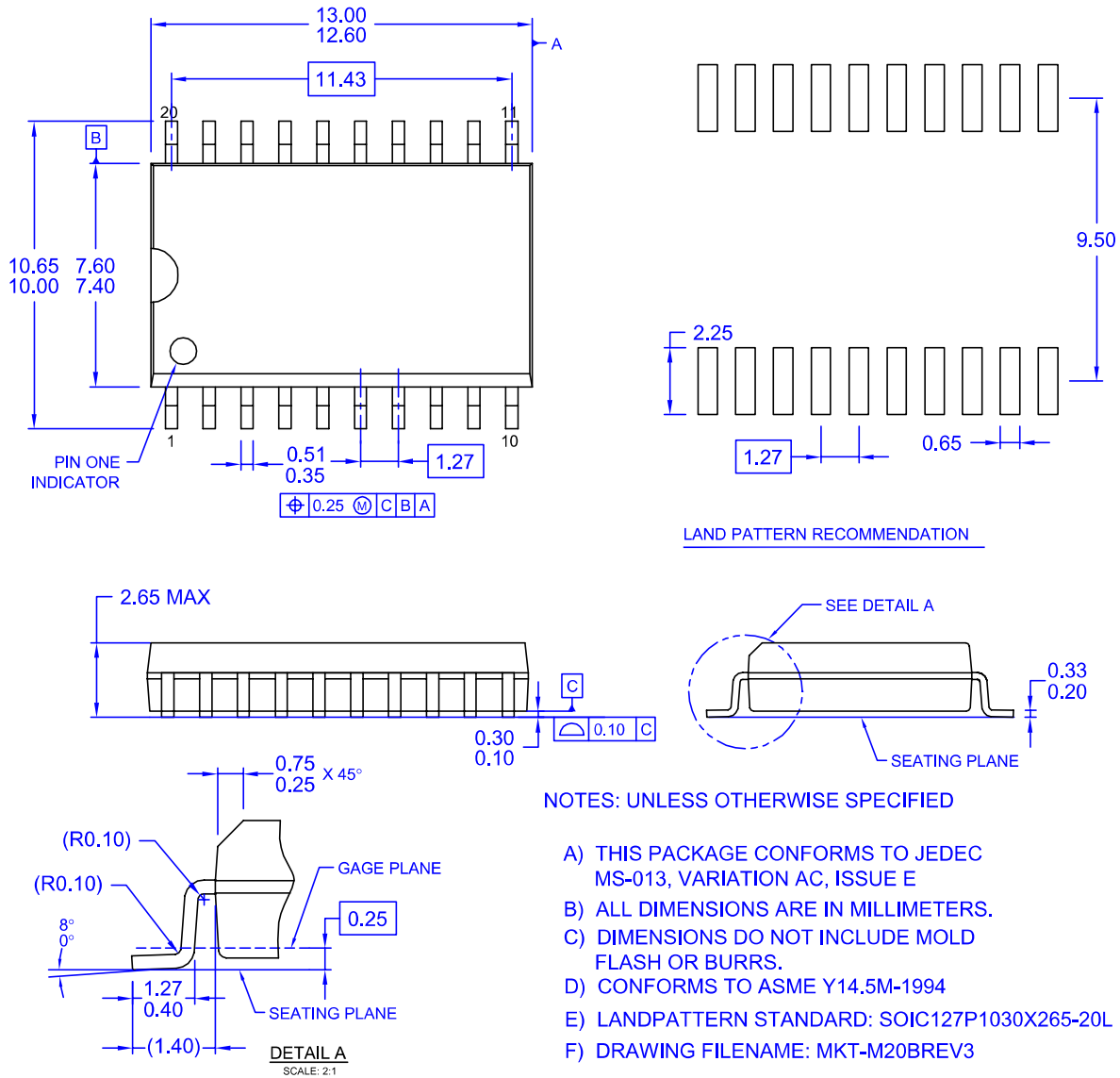

Figure 1. 20-Lead Small Outline Integrated Circuit (SOIC), JEDEC MS-013, 0.300" Wide

Package drawings are provided as a service to customers considering Fairchild components. Drawings may change in any manner without notice. Please note the revision and/or date on the drawing and contact a Fairchild Semiconductor representative to verify or obtain the most recent revision. Package specifications do not expand the terms of Fairchild's worldwide terms and conditions, specifically the warranty therein, which covers Fairchild products.

Always visit Fairchild Semiconductor's online packaging area for the most recent package drawings:

<http://www.fairchildsemi.com/packaging/>

Physical Dimensions (Continued)

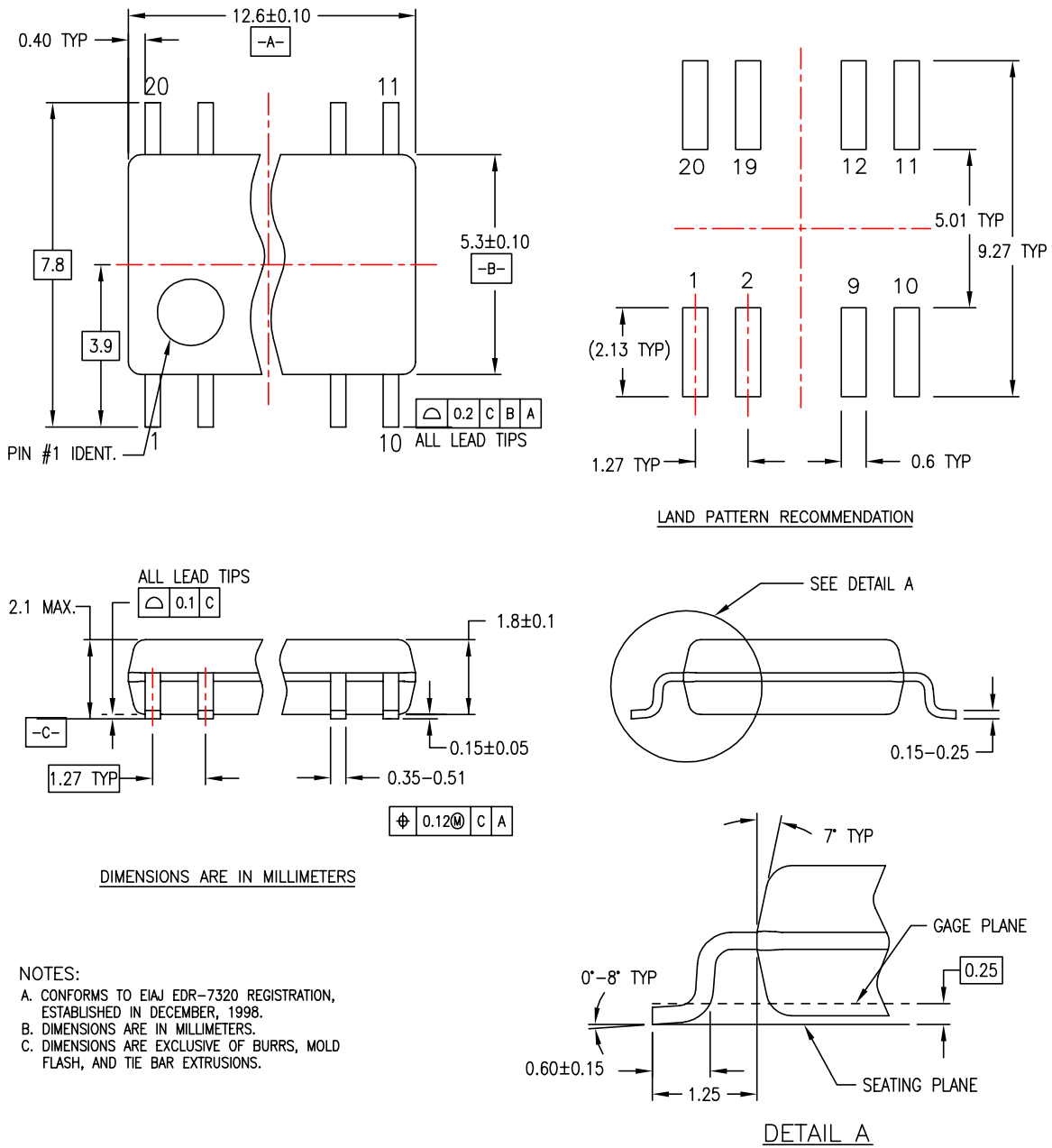

M20DREVC

Figure 2. 20-Lead Small Outline Package (SOP), EIAJ TYPE II, 5.3mm Wide

Package drawings are provided as a service to customers considering Fairchild components. Drawings may change in any manner without notice. Please note the revision and/or date on the drawing and contact a Fairchild Semiconductor representative to verify or obtain the most recent revision. Package specifications do not expand the terms of Fairchild's worldwide terms and conditions, specifically the warranty therein, which covers Fairchild products.

Always visit Fairchild Semiconductor's online packaging area for the most recent package drawings:

<http://www.fairchildsemi.com/packaging/>

Physical Dimensions (Continued)

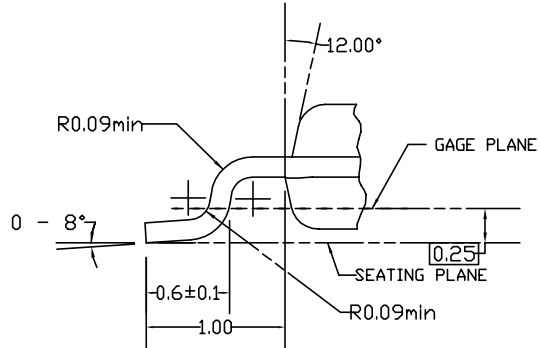
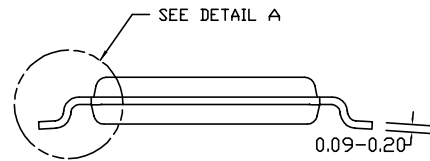
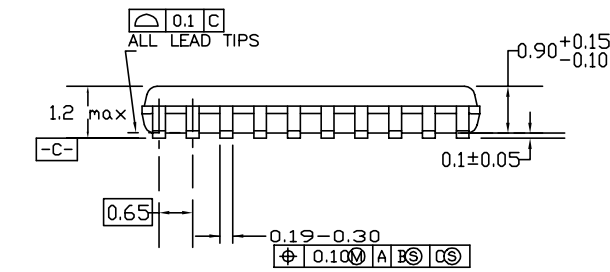
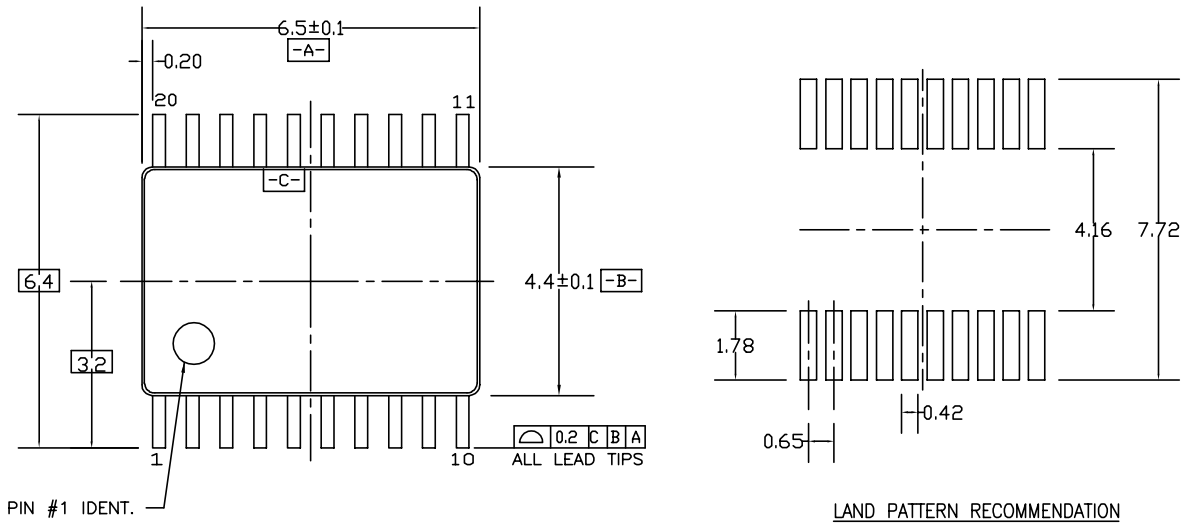

DIMENSIONS ARE IN MILLIMETERS

NOTES:

- A. CONFORMS TO JEDEC REGISTRATION MO-153, VARIATION AC, REF NOTE 6, DATE 7/93.
- B. DIMENSIONS ARE IN MILLIMETERS.
- C. DIMENSIONS ARE EXCLUSIVE OF BURRS, MOLDS FLASH, AND TIE BAR EXTRUSIONS.
- D. DIMENSIONS AND TOLERANCES PER ANSI Y14.5M, 1982.

MTC20REV D1

Figure 3. 20-Lead Thin Shrink Small Outline Package (TSSOP), JEDEC MO-153, 4.4mm Wide

Package drawings are provided as a service to customers considering Fairchild components. Drawings may change in any manner without notice. Please note the revision and/or date on the drawing and contact a Fairchild Semiconductor representative to verify or obtain the most recent revision. Package specifications do not expand the terms of Fairchild's worldwide terms and conditions, specifically the warranty therein, which covers Fairchild products.

Always visit Fairchild Semiconductor's online packaging area for the most recent package drawings:

<http://www.fairchildsemi.com/packaging/>

Physical Dimensions (Continued)

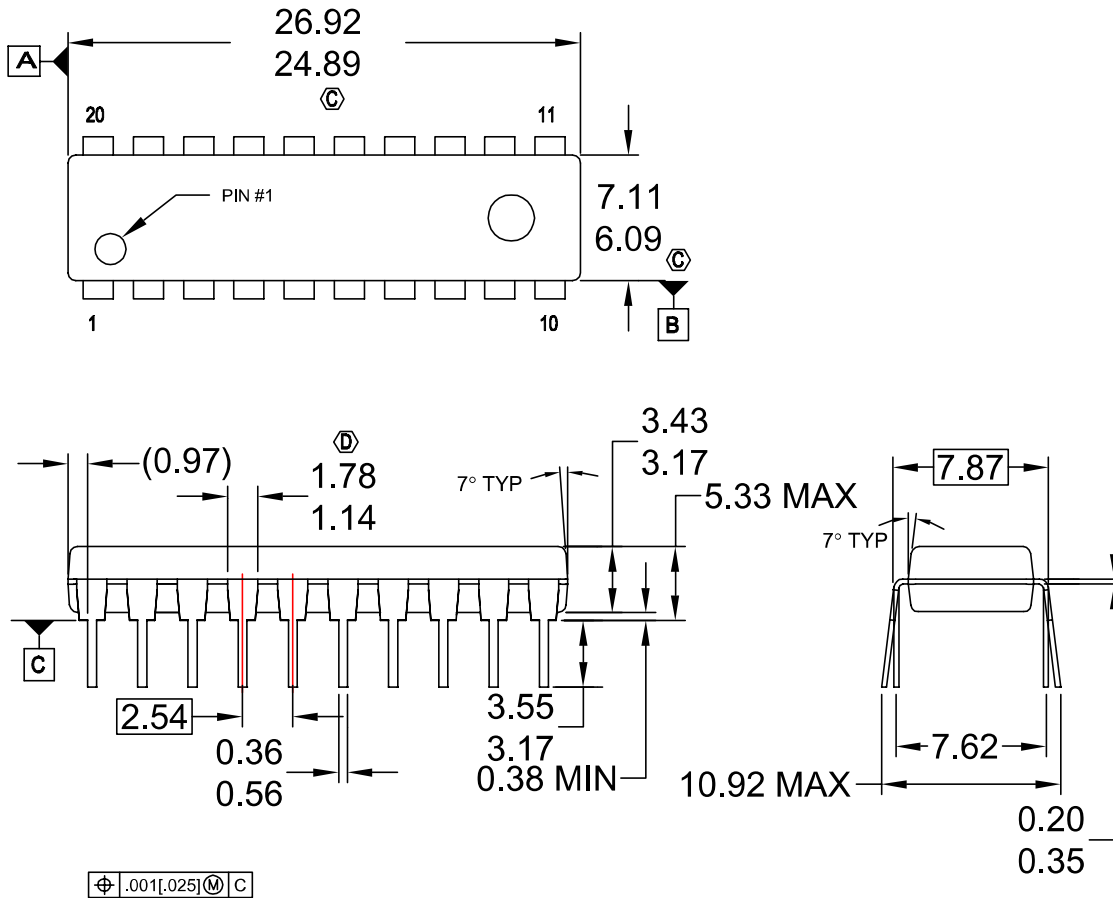

NOTES:

- A. CONFORMS TO JEDEC REGISTRATION MS-001, VARIATIONS AD.
- B. ALL DIMENSIONS ARE IN MILLIMETERS
- \textcircled{C} . DOES NOT INCLUDE MOLD FLASH OR PROTRUSIONS. MOLD FLASH OR PROTRUSIONS SHALL NOT EXCEED 0.25MM.
- \textcircled{D} . DOES NOT INCLUDE DAMBAR PROTRUSIONS. DAMBAR PROTRUSIONS SHALL NOT EXCEED 0.25MM.
- E. DIMENSIONING AND TOLERANCING PER ASME Y14.5M-1994.
- F. DRAWING FILE NAME: N20AREV8

Figure 4. 20-Lead Plastic Dual-In-Line Package (PDIP), JEDEC MS-001, 0.300" Wide

Package drawings are provided as a service to customers considering Fairchild components. Drawings may change in any manner without notice. Please note the revision and/or date on the drawing and contact a Fairchild Semiconductor representative to verify or obtain the most recent revision. Package specifications do not expand the terms of Fairchild's worldwide terms and conditions, specifically the warranty therein, which covers Fairchild products.

Always visit Fairchild Semiconductor's online packaging area for the most recent package drawings:

<http://www.fairchildsemi.com/packaging/>