

SN54LS257B, SN54LS258B, SN54S257, SN54S258 SN74LS257B, SN74LS258B, SN74S257, SN74S258 QUADRUPLE 2-LINE TO 1-LINE DATA SELECTORS/MULTIPLEXERS

SDLS148 - OCTOBER 1976 - REVISED MARCH 1988

- Three-State Outputs Interface Directly with System Bus
- 'LS257B and 'LS258B Offer Three Times the Sink-Current Capability of the Original 'LS257 and 'LS258
- Same Pin Assignments as SN54LS157, SN74LS157, SN54S157, SN74S157, and SN54LS158, SN74LS158, SN54S158, SN74S158
- Provides Bus Interface from Multiple Sources in High-Performance Systems

SN54LS257B, SN54S257,
SN54LS258B, SN54S258 . . . J OR W PACKAGE
SN74LS257B, SN74S257,
SN74LS258B, SN74S258 . . . D OR N PACKAGE
(TOP VIEW)

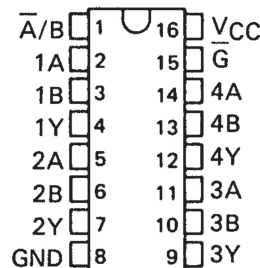

	AVERAGE PROPAGATION DELAY FROM DATA INPUT	TYPICAL POWER DISSIPATION [†]
'LS257B	9 ns	55 mW
'LS258B	9 ns	55 mW
'S257	4.8 ns	320 mW
'S258	4 ns	280 mW

[†] Off state (worst case)

description

These devices are designed to multiplex signals from four-bit data sources to four-output data lines in bus-organized systems. The 3-state outputs will not load the data lines when the output control pin (\bar{G}) is at a high-logic level.

Series 54LS and 54S are characterized for operation over the full military temperature range of -55°C to 125°C ; Series 74LS and 74S are characterized for operation from 0°C to 70°C .

SN54LS257B, SN54S257,
SN54LS258B, SN54S258 . . . FK PACKAGE
(TOP VIEW)

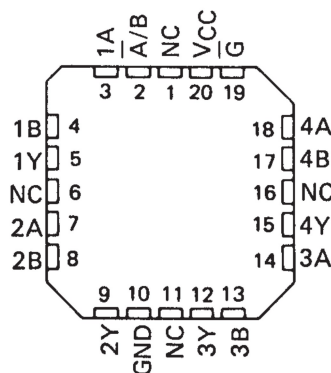

NC-No internal connection.

FUNCTION TABLE

OUTPUT CONTROL	INPUTS		OUTPUT Y		
	SELECT	A	B	'LS257B 'S257	'LS258B 'S258
H	X	X	X	Z	Z
L	L	L	X	L	H
L	L	H	X	H	L
L	H	X	L	L	H
L	H	X	H	H	L

H = high level, L = low level, X = irrelevant,
Z = high impedance (off)

SN54LS257B, SN54LS258B, SN54S257, SN54S258
 SN74LS257B, SN74LS258B, SN74S257, SN74S258
 QUADRUPLE 2-LINE TO 1-LINE DATA SELECTORS/MULTIPLEXERS

SDLS148 – OCTOBER 1976 – REVISED MARCH 1988

logic diagrams (positive logic)

'LS257B, 'S257

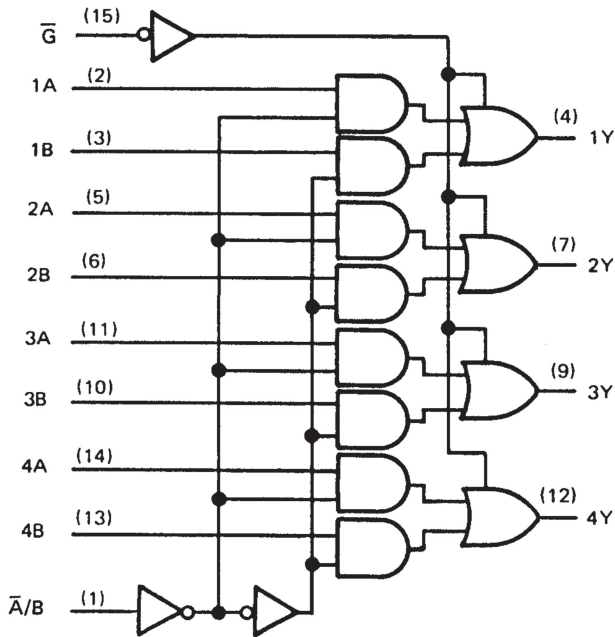

'LS258B, 'S258

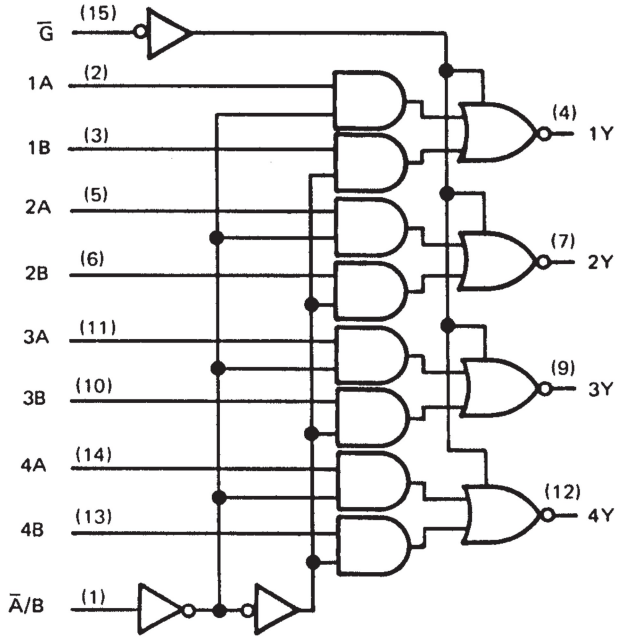

logic symbols†

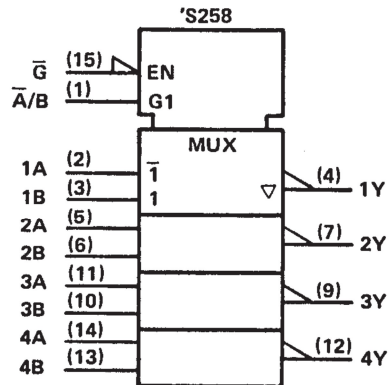
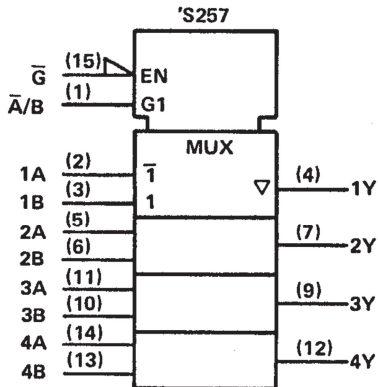
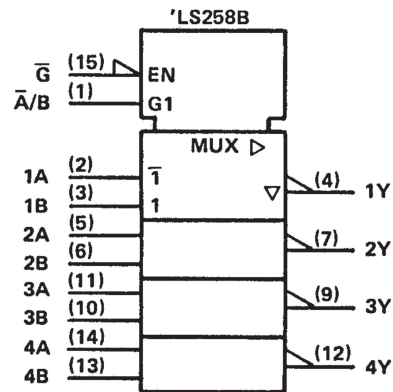
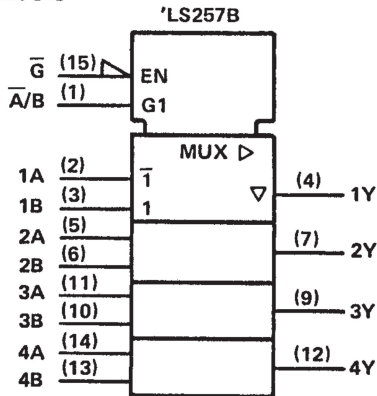

†These symbols are in accordance with ANSI/IEEE Std 91-1984 and IEC Publication 617-12. Pin numbers shown are for D, J, N, and W packages.

SN54LS257B, SN54LS258B, SN54S257, SN54S258 SN74LS257B, SN74LS258B, SN74S257, SN74S258 QUADRUPLE 2-LINE TO 1-LINE DATA SELECTORS/MULTIPLEXERS

SDLS148 – OCTOBER 1976 – REVISED MARCH 1988

schematics of inputs and outputs

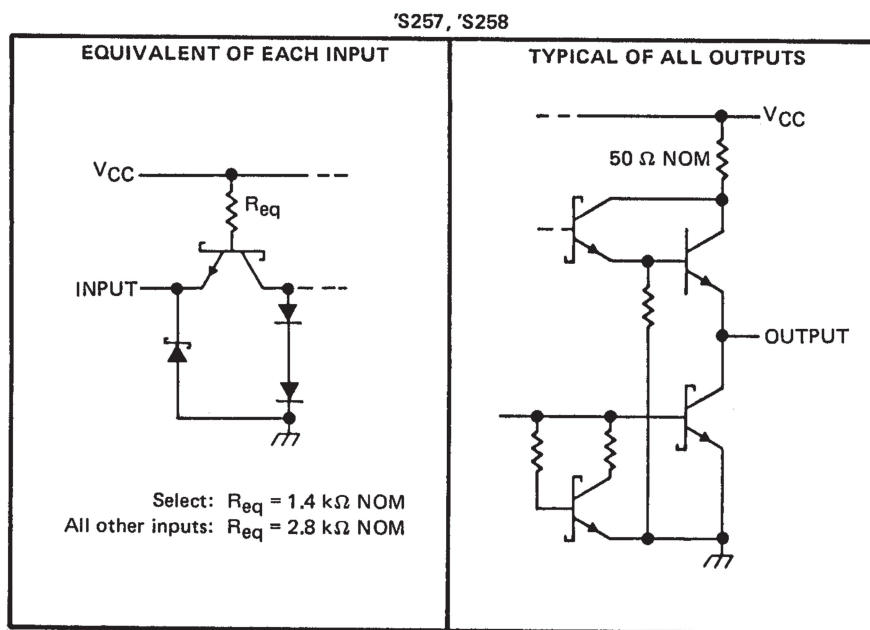
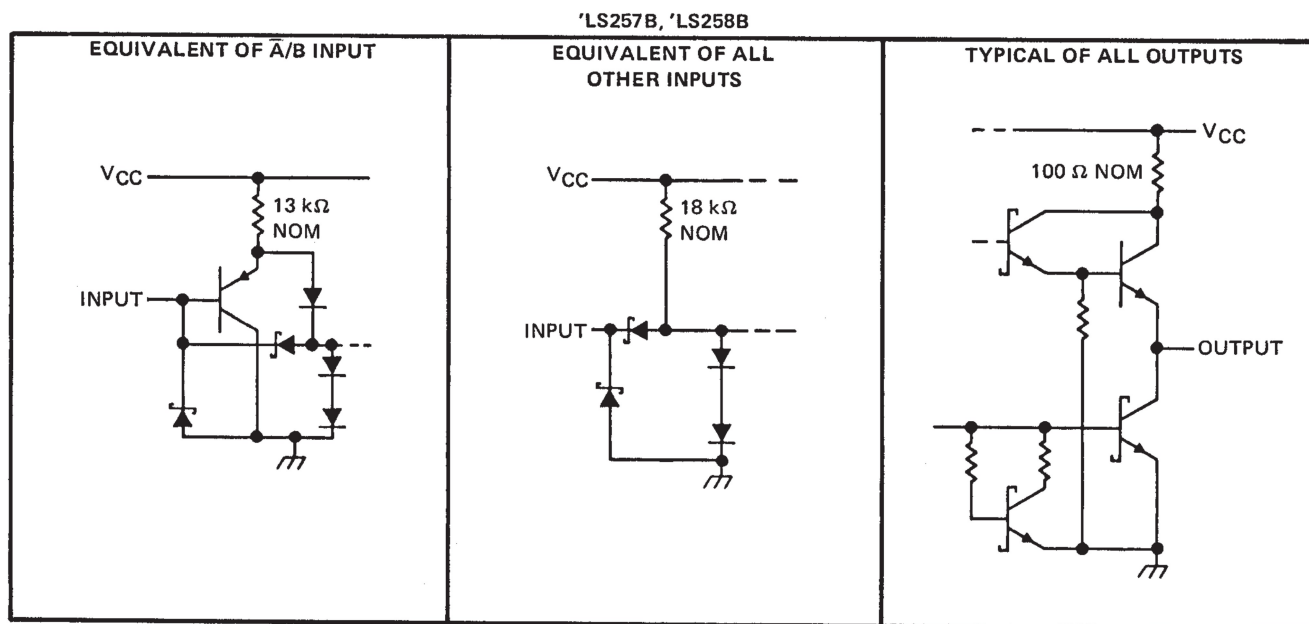

absolute maximum ratings over operating free-air temperature range (unless otherwise noted)

Supply voltage, V_{CC} (see Note 1)	7 V
Input voltage: 'LS257B, 'LS258B Circuits	7 V
'S257, 'S258 Circuits	5.5 V
Off-state output voltage	5.5 V
Operating free-air temperature range: SN54LS', SN54S' Circuits	-55°C to 125°C
SN74LS', SN74S' Circuits	0°C to 70°C
Storage temperature range	-65°C to 150°C

NOTE 1: Voltage values are with respect to network ground terminal.

**SN54LS257B, SN54LS258B, SN54S257, SN54S258
SN74LS257B, SN74LS258B, SN74S257, SN74S258
QUADRUPLE 2-LINE TO 1-LINE DATA SELECTORS/MULTIPLEXERS**

SDLS148 – OCTOBER 1976 – REVISED MARCH 1988

recommended operating conditions

	SN54LS'			SN74LS'			UNIT
	MIN	NOM	MAX	MIN	NOM	MAX	
V _{CC} Supply voltage	4.5	5	5.5	4.75	5	5.25	V
V _{IH} High-level input voltage	2			2			V
V _{IL} Low-level input voltage			0.7			0.8	V
I _{OH} High-level output current			-1			-2.6	mA
I _{OL} Low-level output current			12			24	mA
T _A Operating free-air temperature	-55		125	0		70	°C

electrical characteristics over recommended operating free-air temperature range (unless otherwise noted)

PARAMETER	TEST CONDITIONS†	SN54LS'			SN74LS'			UNIT	
		MIN	TYP‡	MAX	MIN	TYP‡	MAX		
V _{IK}	V _{CC} = MIN, I _I = -18 mA			-1.5			-1.5	V	
V _{OH}	V _{CC} = MIN, V _{IH} = 2 V, V _{IL} = MAX, I _{OH} = MAX	2.4	3.4		2.4	3.1		V	
V _{OL}	V _{CC} = MIN, V _{IH} = 2 V, V _{IL} = MAX, I _{OL} = 12 mA		0.25	0.4		0.25	0.4	V	
						0.35	0.5		
I _{OZH}	V _{CC} = MAX, V _{IH} = 2 V, V _O = 2.7 V			20			20	μA	
I _{OZL}	V _{CC} = MAX, V _{IH} = 2 V, V _O = 0.4 V			-20			-20	μA	
I _I	V _{CC} = MAX, V _I = 7 V			0.1			0.1	mA	
I _{IH}	V _{CC} = MAX, V _I = 2.7 V			20			20	μA	
I _{IL}	V _{CC} = MAX, V _I = 0.4 V			-0.4			-0.4	mA	
I _{OS} §	V _{CC} = MAX,	-30		-130	-30		-130	mA	
I _{CC}	All outputs high	V _{CC} = MAX, See Note 2		'LS257B	8	12	8	12	mA
	All outputs low				12	18	12	18	
	All outputs off				13	19	13	19	
	All outputs high				6	9	6	9	
	All outputs low				10	15	10	15	
	All outputs off				11	16	11	16	

† For conditions shown as MIN or MAX, use the appropriate value specified under recommended operating conditions.

‡ All typical values are at V_{CC} = 5 V, T_A = 25°C.

§ Not more than one output should be shorted at a time and duration of the short-circuit should not exceed one second.

NOTE 2: I_{CC} is measured with all outputs open and all possible inputs grounded while achieving the stated output conditions.

switching characteristics, V_{CC} = 5 V, T_A = 25°C, R_L = 667 Ω

PARAMETER †	FROM (INPUT)	TO (OUTPUT)	TEST CONDITIONS	'LS257B			'LS258B			UNIT
				MIN	TYP	MAX	MIN	TYP	MAX	
t _{PLH}	Data	Any	C _L = 45 pF, See Note 3	8	13		7	12	ns	
t _{PHL}				10	15		11	17		
t _{PLH}	Select	Any		16	21		14	21	ns	
t _{PHL}				17	24		19	24		
t _{PZH}	Output	Any		15	30		15	30	ns	
t _{PZL}	Control			19	30		20	30		
t _{PHZ}	Output	Any	C _L = 5 pF, See Note 3	18	30		18	30	ns	
t _{PLZ}			Control	16	25		16	25		

† t_{PLH} = propagation delay time, low-to-high-level output

t_{PHL} = propagation delay time, high-to-low-level output

t_{PZH} = output enable time to high level

t_{PZL} = output enable time to low level

t_{PHZ} = output disable time from high level

t_{PLZ} = output disable time from low level

NOTE 3: Load circuits and voltage waveforms are shown in Section 1.



**SN54LS257B, SN54LS258B, SN54S257, SN54S258
SN74LS257B, SN74LS258B, SN74S257, SN74S258
QUADRUPLE 2-LINE TO 1-LINE DATA SELECTORS/MULTIPLEXERS**

SDLS148 – OCTOBER 1976 – REVISED MARCH 1988

recommended operating conditions

	SN54S'			SN74S'			UNIT
	MIN	NOM	MAX	MIN	NOM	MAX	
Supply voltage, V_{CC}	4.5	5	5.5	4.75	5	5.25	V
High-level output current, I_{OH}			-2			-6.5	mA
Low-level output current, I_{OL}			20			20	mA
Operating free-air temperature, T_A	-55		125	0		70	°C

electrical characteristics over recommended operating free-air temperature range (unless otherwise noted)

PARAMETER		TEST CONDITIONS†	'S257			'S258			UNIT
			MIN	TYP‡	MAX	MIN	TYP‡	MAX	
V_{IH}	High-level input voltage		2			2			V
V_{IL}	Low-level input voltage		0.8			0.8			V
V_{IK}	Input clamp voltage	$V_{CC} = \text{MIN}, I_I = -18 \text{ mA}$	-1.2			-1.2			V
V_{OH}	High-level output voltage	$V_{CC} = \text{MIN}, V_{IH} = 2 \text{ V}, V_{IL} = 0.8 \text{ V}, I_{OH} = -1 \text{ mA}$ SN74S'	2.7			2.7			V
		$V_{CC} = \text{MIN}, V_{IH} = 2 \text{ V}, V_{IL} = 0.8 \text{ V}, I_{OH} = \text{MAX}$ SN54S'	2.4	3.4		2.4	3.4		
		$V_{CC} = \text{MIN}, V_{IH} = 2 \text{ V}, V_{IL} = 0.8 \text{ V}, I_{OH} = \text{MAX}$ SN74S'	2.4	3.2		2.4	3.2		
V_{OL}	Low-level output voltage	$V_{CC} = \text{MIN}, V_{IH} = 2 \text{ V}, V_{IL} = 0.8 \text{ V}, I_{OL} = 20 \text{ mA}$	0.5			0.5			V
I_{OZH}	Off-state output current, high-level voltage applied	$V_{CC} = \text{MAX}, V_{IH} = 2 \text{ V}, V_O = 2.4 \text{ V}$	50			50			μA
I_{OZL}	Off-state output current, low-level voltage applied	$V_{CC} = \text{MAX}, V_{IH} = 2 \text{ V}, V_O = 0.5 \text{ V}$	-50			-50			μA
I_I	Input current at maximum input voltage	$V_{CC} = \text{MAX}, V_I = 5.5 \text{ V}$	1			1			mA
I_{IH}	High-level input current	S input	100			100			μA
		Any other	50			50			
I_{IL}	Low-level input current	S input	-4			-4			mA
		Any other	-2			-2			
I_{OS}	Short-circuit output current§	$V_{CC} = \text{MAX}$	-40		-100	-40		-100	mA
I_{CC}	Supply current	All outputs high	44			68			mA
		All outputs low	60			93			
		All outputs off	64			99			

†For conditions shown as MIN or MAX, use the appropriate value specified under recommended operating conditions.

‡All typical values are at $V_{CC} = 5 \text{ V}, T_A = 25^\circ\text{C}$.

§Not more than one output should be shorted at a time and duration of the short-circuit should not exceed one second.

NOTE 2: I_{CC} is measured with all outputs open and all possible inputs grounded while achieving the stated output conditions.

switching characteristics, $V_{CC} = 5 \text{ V}, T_A = 25^\circ\text{C}, R_L = 280 \Omega$

PARAMETER¶	FROM (INPUT)	TO (OUTPUT)	TEST CONDITIONS	'S257			'S258			UNIT
				MIN	TYP	MAX	MIN	TYP	MAX	
t_{PLH}	Data	Any	$C_L = 15 \text{ pF},$ See Note 3	5	7.5		4	6	ns	
t_{PHL}				4.5	6.5		4	6		
t_{PLH}	Select	Any		8.5	15		8	12	ns	
t_{PHL}				8.5	15		7.5	12		
t_{pZH}	Output	Any		13	19.5		13	19.5	ns	
t_{pZL}	Control			14	21		14	21		
t_{PHZ}	Output	Any		5.5	8.5		5.5	8.5	ns	
t_{PLZ}	Control			9	14		9	14		

¶ f_{max} = Maximum clock frequency

t_{PLH} = propagation delay time, low-to-high-level output

t_{PHL} = propagation delay time, high-to-low-level output

t_{pZH} = output enable time to high level

t_{pZL} = output enable time to low level

t_{PHZ} = output disable time from high level

t_{PLZ} = output disable time from low level

NOTE 3: Load circuits and voltage waveforms are shown in Section 1.

