

LMx35, LMx35A Precision Temperature Sensors

1 Features

- Directly Calibrated to the Kelvin Temperature Scale
- 1°C Initial Accuracy Available
- Operates from 400 μ A to 5 mA
- Less than 1- Ω Dynamic Impedance
- Easily Calibrated
- Wide Operating Temperature Range
- 200°C Overrange
- Low Cost

2 Applications

- Power Supplies
- Battery Management
- HVAC
- Appliances

3 Description

The LM135 series are precision, easily-calibrated, integrated circuit temperature sensors. Operating as a 2-terminal zener, the LM135 has a breakdown voltage directly proportional to absolute temperature at 10 mV/°K. With less than 1- Ω dynamic impedance, the device operates over a current range of 400 μ A to 5 mA with virtually no change in performance. When calibrated at 25°C, the LM135 has typically less than 1°C error over a 100°C temperature range. Unlike other sensors, the LM135 has a linear output.

Applications for the LM135 include almost any type of temperature sensing over a -55°C to 150°C temperature range. The low impedance and linear output make interfacing to readout or control circuitry are especially easy.

The LM135 operates over a -55°C to 150°C temperature range while the LM235 operates over a -40°C to 125°C temperature range. The LM335 operates from -40°C to 100°C. The LMx35 devices are available packaged in hermetic TO transistor packages while the LM335 is also available in plastic TO-92 packages.

Device Information⁽¹⁾

PART NUMBER	PACKAGE	BODY SIZE (NOM)
LM135	TO-46 (3)	4.699 mm × 4.699 mm
LM135A		
LM235	TO-92 (3)	4.30 mm × 4.30 mm
LM235A		
LM335	SOIC (8)	4.90 mm × 3.91 mm
LM335A		

(1) For all available packages, see the orderable addendum at the end of the datasheet.

Basic Temperature Sensor Simplified Schematic

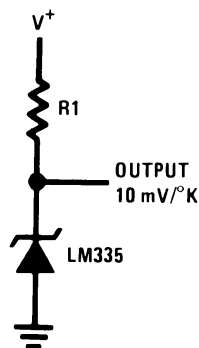

Calibrated Sensor

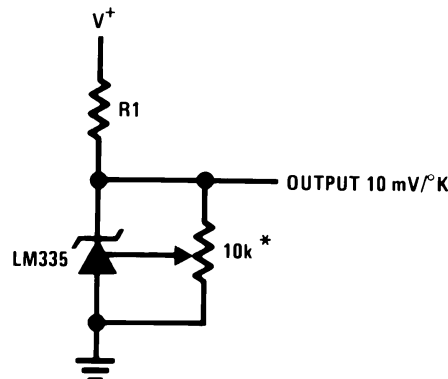

Table of Contents

1 Features	1	8 Application and Implementation	10
2 Applications	1	8.1 Application Information.....	10
3 Description	1	8.2 Typical Application	10
4 Revision History	2	8.3 System Examples	11
5 Pin Configuration and Functions	3	9 Power Supply Recommendations	16
6 Specifications	4	10 Layout	16
6.1 Absolute Maximum Ratings	4	10.1 Layout Guidelines	16
6.2 Recommended Operating Conditions	4	10.2 Layout Example	16
6.3 Thermal Information	4	10.3 Waterproofing Sensors	17
6.4 Temperature Accuracy: LM135/LM235, LM135A/LM235A	4	10.4 Mounting the Sensor at the End of a Cable.....	17
6.5 Temperature Accuracy: LM335, LM335A ⁽¹⁾	5	11 Device and Documentation Support	18
6.6 Electrical Characteristics.....	5	11.1 Device Support.....	18
6.7 Typical Characteristics	6	11.2 Related Links	18
7 Detailed Description	8	11.3 Trademarks	18
7.1 Overview	8	11.4 Electrostatic Discharge Caution.....	18
7.2 Functional Block Diagram	8	11.5 Glossary	18
7.3 Feature Description.....	8	12 Mechanical, Packaging, and Orderable Information	18
7.4 Device Functional Modes.....	9		

4 Revision History

NOTE: Page numbers for previous revisions may differ from page numbers in the current version.

Changes from Revision D (March 2013) to Revision E	Page
<ul style="list-style-type: none"> Added <i>Pin Configuration and Functions</i> section, <i>Feature Description</i> section, <i>Device Functional Modes</i>, <i>Application and Implementation</i> section, <i>Power Supply Recommendations</i> section, <i>Layout</i> section, <i>Device and Documentation Support</i> section, and <i>Mechanical, Packaging, and Orderable Information</i> section..... 	1

Changes from Revision C (November 2012) to Revision D	Page
<ul style="list-style-type: none"> Changed layout of National Data Sheet to TI format 	18

5 Pin Configuration and Functions

TO-46 (NDV)
3 Pins
Bottom View

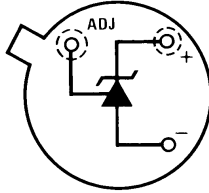

TO-92 (LP)
3 Pins
Bottom View

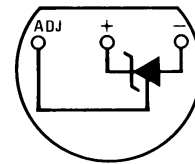

SOIC (D)
8 Pins
Top View

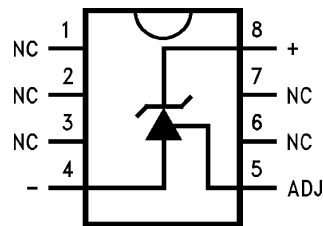

Pin Functions

NAME	PIN			I/O	DESCRIPTION
	TO-46	TO-92	SO8		
N.C.	—	—	1	—	No Connection
	—	—	2		
	—	—	3		
-	—	—	4	O	Negative output
ADJ	—	—	5	I	Calibration adjust pin
N.C.	—	—	6	—	No Connection
	—	—	7		
+	—	—	8	I	Positive input

6 Specifications

6.1 Absolute Maximum Ratings

 over operating free-air temperature range (unless otherwise noted)⁽¹⁾⁽²⁾⁽³⁾⁽⁴⁾

		MIN	MAX	UNIT
Reverse Current			15	mA
Forward Current			10	mA
Storage temperature, T_{stg}	8-Pin SOIC Package	-65	150	°C
	TO / TO-92 Package	-60	150	°C

- (1) Stresses beyond those listed under *Absolute Maximum Ratings* may cause permanent damage to the device. These are stress ratings only, which do not imply functional operation of the device at these or any other conditions beyond those indicated under *Recommended Operating Conditions*. Exposure to absolute-maximum-rated conditions for extended periods may affect device reliability.
- (2) Refer to RETS135H for military specifications.
- (3) If Military/Aerospace specified devices are required, please contact the TI Sales Office/Distributors for availability and specifications.
- (4) Soldering process must comply with the Reflow Temperature Profile specifications. Refer to <http://www.ti.com/packaging>.

6.2 Recommended Operating Conditions

over operating free-air temperature range (unless otherwise noted)

			MIN	NOM	MAX	UNIT
Specified Temperature	LM135, LM135A	Continuous ($T_{MIN} \leq T_A \leq T_{MAX}$)	-55		150	°C
		Intermittent ⁽¹⁾	150		200	
	LM235, LM235A	Continuous ($T_{MIN} \leq T_A \leq T_{MAX}$)	-40		125	°C
		Intermittent ⁽¹⁾	125		150	
	LM335, LM335A	Continuous ($T_{MIN} \leq T_A \leq T_{MAX}$)	-40		100	°C
		Intermittent ⁽¹⁾	100		125	
Forward Current			0.4	1	5	mA

- (1) Continuous operation at these temperatures for 5,000 hours for LP package may decrease life expectancy of the device.

6.3 Thermal Information

THERMAL METRIC ⁽¹⁾		LM335 / LM335A	LM235 / LM235A	LM135 / LM135A	UNIT
		SOIC (D)	TO-92 (LP)	TO-46 (NDV)	
		8 PINS	3 PINS	3 PINS	
$R_{\theta JA}$	Junction-to-ambient thermal resistance	165	202	400	°C/W
$R_{\theta JC}$	Junction-to-case thermal resistance	—	170	—	

- (1) For more information about traditional and new thermal metrics, see the *IC Package Thermal Metrics* application report, [SPRA953](http://www.ti.com/lit/zip/SPR953).

6.4 Temperature Accuracy: LM135/LM235, LM135A/LM235A⁽¹⁾

PARAMETER		TEST CONDITIONS	LM135A/LM235A			LM135/LM235			UNIT
			MIN	TYP	MAX	MIN	TYP	MAX	
Operating Output Voltage		$T_C = 25^\circ\text{C}$, $I_R = 1\text{ mA}$	2.97	2.98	2.99	2.95	2.98	3.01	V
Uncalibrated Temperature Error		$T_C = 25^\circ\text{C}$, $I_R = 1\text{ mA}$		0.5	1		1	3	°C
Uncalibrated Temperature Error		$T_{MIN} \leq T_C \leq T_{MAX}$, $I_R = 1\text{ mA}$		1.3	2.7		2	5	°C
Temperature Error with 25°C		$T_{MIN} \leq T_C \leq T_{MAX}$, $I_R = 1\text{ mA}$		0.3	1		0.5	1.5	°C
Calibration	Calibrated Error at Extended	$T_C = T_{MAX}$ (Intermittent)		2			2		°C
Temperature	Non-Linearity	$I_R = 1\text{ mA}$		0.3	0.5		0.3	1	°C

- (1) Accuracy measurements are made in a well-stirred oil bath. For other conditions, self heating must be considered.

6.5 Temperature Accuracy: LM335, LM335A⁽¹⁾

PARAMETER		TEST CONDITIONS	LM335A			LM335			UNIT
			MIN	TYP	MAX	MIN	TYP	MAX	
Operating Output Voltage		$T_C = 25^\circ\text{C}$, $I_R = 1\text{ mA}$	2.95	2.98	3.01	2.92	2.98	3.04	V
Uncalibrated Temperature Error		$T_C = 25^\circ\text{C}$, $I_R = 1\text{ mA}$	1		3	2		6	$^\circ\text{C}$
Uncalibrated Temperature Error		$T_{\text{MIN}} \leq T_C \leq T_{\text{MAX}}$, $I_R = 1\text{ mA}$	2		5	4		9	$^\circ\text{C}$
Temperature Error with 25°C		$T_{\text{MIN}} \leq T_C \leq T_{\text{MAX}}$, $I_R = 1\text{ mA}$	0.5		1	1		2	$^\circ\text{C}$
Calibration	Calibrated Error at Extended	$T_C = T_{\text{MAX}}$ (Intermittent)	2			2			$^\circ\text{C}$
Temperature	Non-Linearity	$I_R = 1\text{ mA}$	0.3		1.5	0.3		1.5	$^\circ\text{C}$

(1) Accuracy measurements are made in a well-stirred oil bath. For other conditions, self heating must be considered.

6.6 Electrical Characteristics

See ⁽¹⁾.

PARAMETER	TEST CONDITIONS	LM135/LM235/LM135A/LM235A			LM335/LM335A			UNIT
		MIN	TYP	MAX	MIN	TYP	MAX	
Operating Output Voltage Change with Current	$400\ \mu\text{A} \leq I_R \leq 5\text{ mA}$, At Constant Temperature		2.5	10		3	14	mV
Dynamic Impedance	$I_R = 1\text{ mA}$		0.5			0.6		Ω
Output Voltage Temperature Coefficient			10			10		mV/ $^\circ\text{C}$
Time Constant	Still Air		80			80		sec
	100 ft/Min Air		10			10		sec
	Stirred Oil		1			1		sec
Time Stability	$T_C = 125^\circ\text{C}$		0.2			0.2		$^\circ\text{C}/\text{hr}$

(1) Accuracy measurements are made in a well-stirred oil bath. For other conditions, self heating must be considered.

6.7 Typical Characteristics

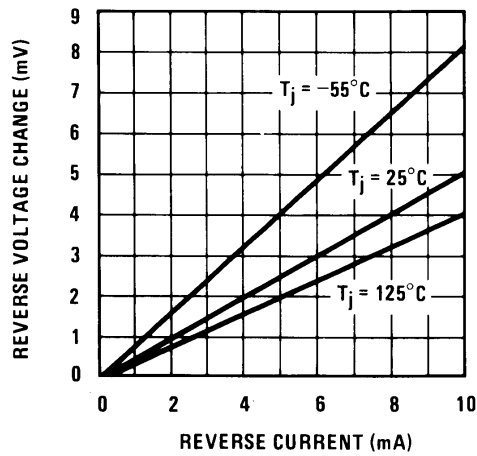
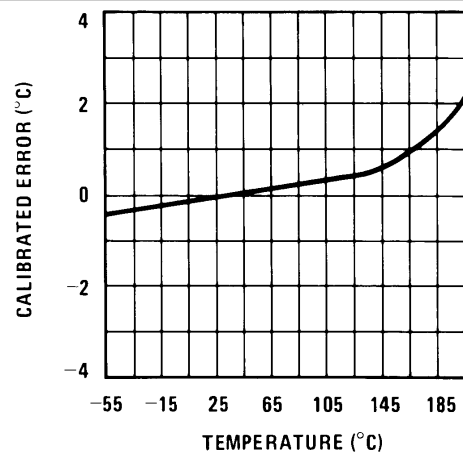
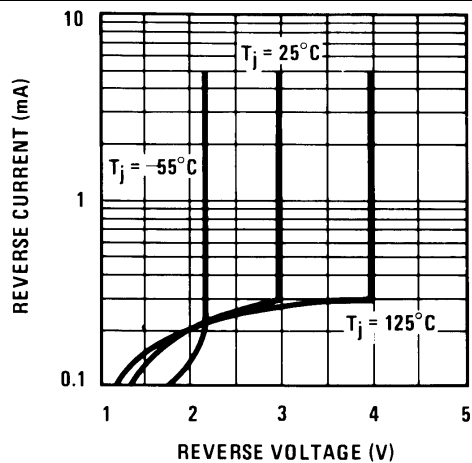
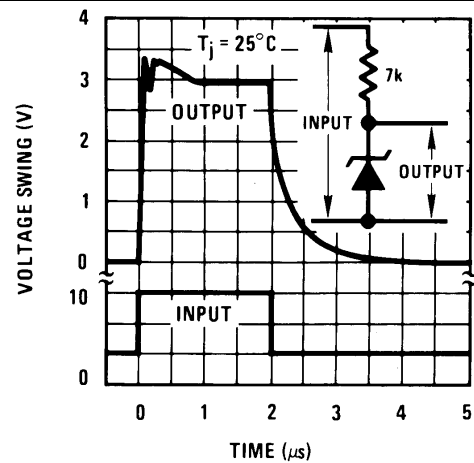
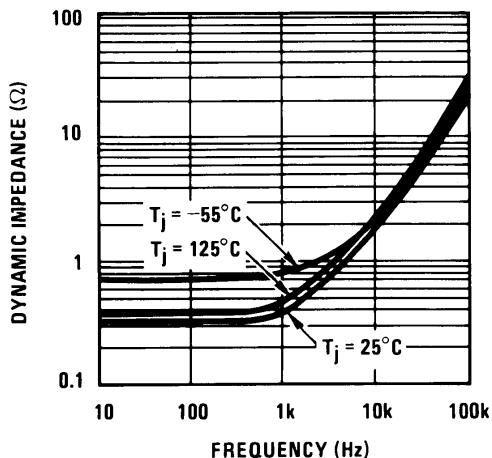
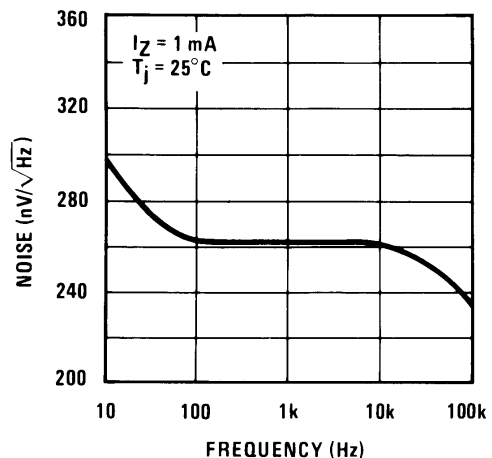
Figure 1. Reverse Voltage Change

Figure 2. Calibrated Error

Figure 3. Reverse Characteristics

Figure 4. Response Time

Figure 5. Dynamic Impedance

Figure 6. Noise Voltage

Typical Characteristics (continued)

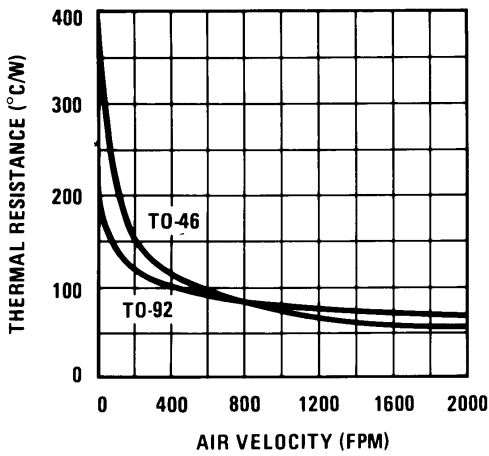

Figure 7. Thermal Resistance Junction To Air

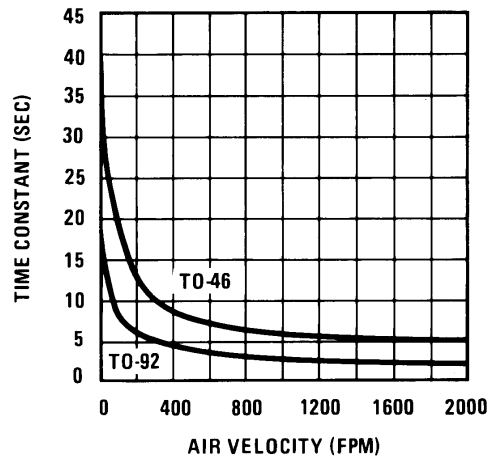

Figure 8. Thermal Time Constant

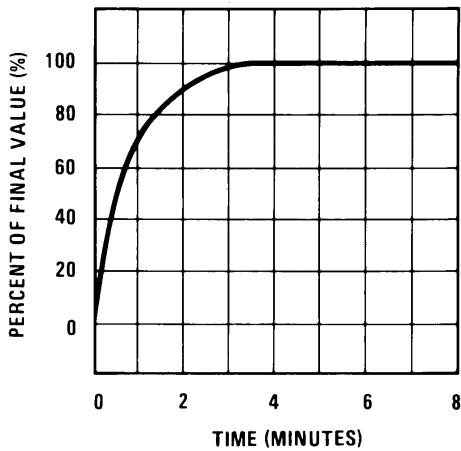

Figure 9. Thermal Response In Still Air

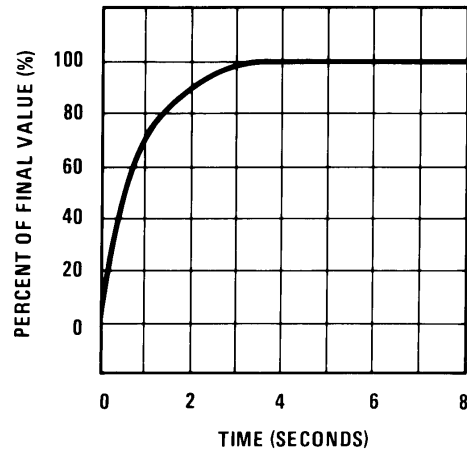

Figure 10. Thermal Response In Stirred Oil Bath

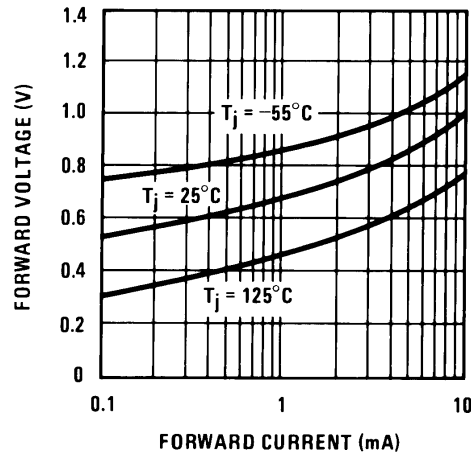

Figure 11. Forward Characteristics

7 Detailed Description

7.1 Overview

Applications for the LM135 include almost any type of temperature sensing over a -55°C to 150°C temperature range. The low impedance and linear output make interfacing to readout or control circuitry especially easy.

The LM135 operates over a -55°C to 150°C temperature range while the LM235 operates over a -40°C to 125°C temperature range. The LM335 operates from -40°C to 100°C .

Operating as a 2-terminal zener, the LM135 has a breakdown voltage directly proportional to absolute temperature at $10\text{ mV}/^{\circ}\text{K}$. With less than $1\text{-}\Omega$ dynamic impedance, the device operates over a current range of $400\text{ }\mu\text{A}$ to 5 mA with virtually no change in performance. When calibrated at 25°C , the LM135 has typically less than 1°C error over a 100°C temperature range. Unlike other sensors, the LM135 has a linear output.

7.2 Functional Block Diagram

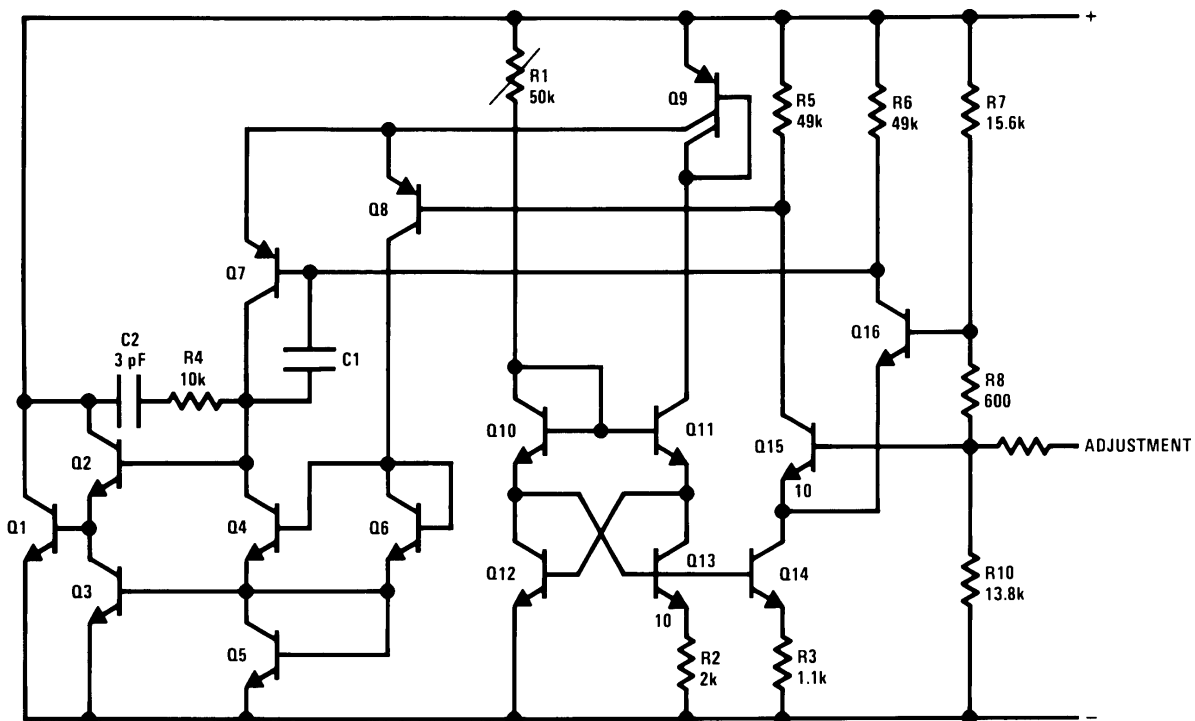

7.3 Feature Description

7.3.1 Temperature Calibration Using ADJ Pin

Included on the LM135 chip is an easy method of calibrating the device for higher accuracies. A pot connected across the LM135 with the arm tied to the adjustment terminal (as shown in [Figure 12](#)) allows a 1-point calibration of the sensor that corrects for inaccuracy over the full temperature range.

This single point calibration works because the output of the LM135 is proportional to absolute temperature with the extrapolated output of sensor going to 0-V output at 0 K (-273.15°C). Errors in output voltage versus temperature are only slope (or scale factor) errors so a slope calibration at one temperature corrects at all temperatures.

The output of the device (calibrated or uncalibrated) can be expressed as:

$$V_{\text{OUT}_T} = V_{\text{OUT}_{T_0}} \times \frac{T}{T_0}$$

where

Feature Description (continued)

- T is the unknown temperature in degrees Kelvin
- T_o is a reference temperature in degrees Kelvin (1)

By calibrating the output to read correctly at one temperature the output at all temperatures is correct. Nominally the output is calibrated at 10 mV/K.

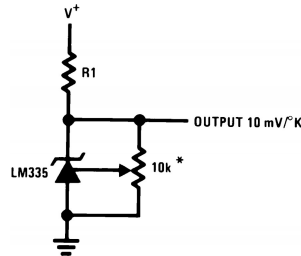

Calibrate for 2.982V at 25°C

Figure 12. Calibrated Sensor

7.4 Device Functional Modes

The LM135 has two functional modes calibrated and uncalibrated. For optimum accuracy, a one point calibration is recommended. For more information on calibration, see [Temperature Calibration Using ADJ Pin](#).

8 Application and Implementation

NOTE

Information in the following applications sections is not part of the TI component specification, and TI does not warrant its accuracy or completeness. TI's customers are responsible for determining suitability of components for their purposes. Customers should validate and test their design implementation to confirm system functionality.

8.1 Application Information

To insure good sensing accuracy, several precautions must be taken. Like any temperature-sensing device, self-heating can reduce accuracy. The LM135 should be operated at the lowest current suitable for the application. Sufficient current, of course, must be available to drive both the sensor and the calibration pot at the maximum operating temperature as well as any external loads.

If the sensor is used in an ambient where the thermal resistance is constant, self-heating errors can be calibrated out. This is possible if the device is run with a temperature-stable current. Heating will then be proportional to zener voltage and therefore temperature. This makes the self-heating error proportional to absolute temperature the same as scale factor errors.

8.2 Typical Application

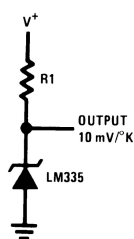

Figure 13. Basic Temperature Sensor

8.2.1 Design Requirements

Table 1. Design Parameters

PARAMETER	EXAMPLE VALUE
Accuracy at 25°C	±1°C
Accuracy from –55 °C to 150 °C	±2.7°C
Forward Current	1 mA
Temperature Slope	10m V/K

8.2.2 Detailed Design Procedure

For optimum accuracy, R1 is picked such that 1 mA flows through the sensor. Additional error can be introduced by varying load currents or varying supply voltage. The influence of these currents on the minimum and maximum reverse current flowing through the LM135 should be calculated and be maintained in the range of 0.4 mA to 5 mA. Minimizing the current variation through the LM135 will provide for the best accuracy. The Operating Output Voltage Change with Current specification can be used to calculate the additional error which could be up to 1 K maximum from the LM135A, for example.

8.2.3 Application Curve

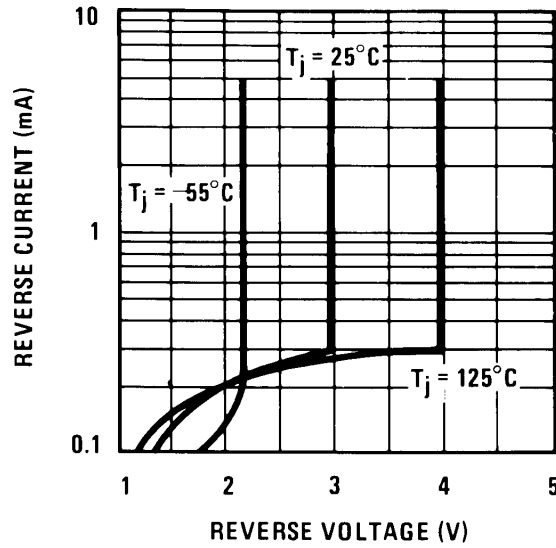

Figure 14. Reverse Characteristics

8.3 System Examples

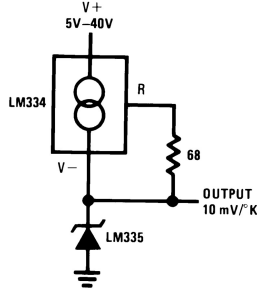

Figure 15. Wide Operating Supply

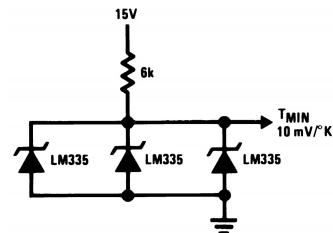

Figure 16. Minimum Temperature Sensing

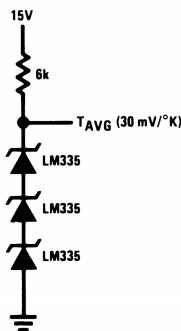

Figure 17. Average Temperature Sensing

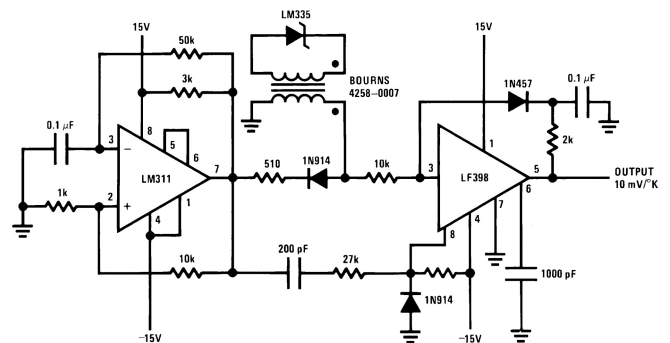

Figure 18. Isolated Temperature Sensor

Wire length for 1°C error due to wire drop

System Examples (continued)

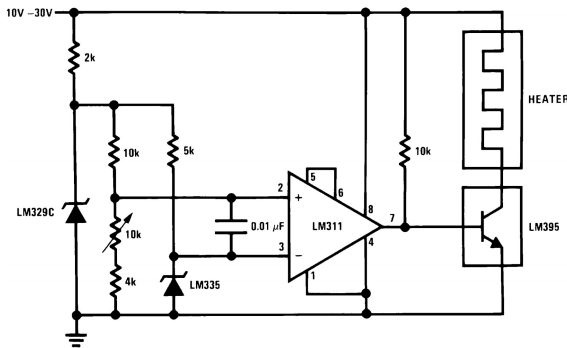

Figure 19. Simple Temperature Controller

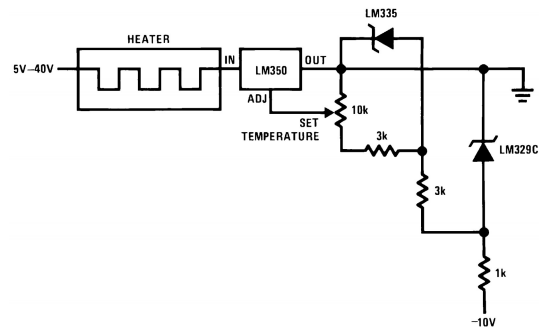
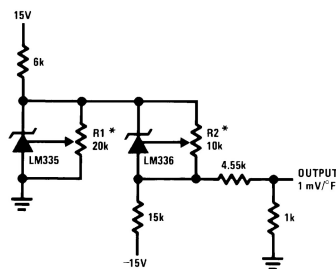
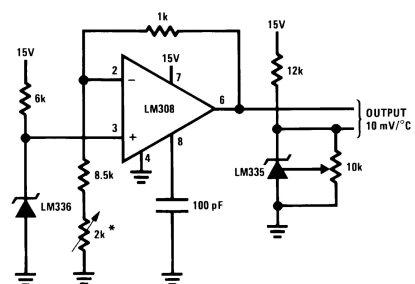

Figure 20. Simple Temperature Control



Adjust R2 for 2.554V across LM336.
Adjust R1 for correct output.

Figure 21. Ground Referred Fahrenheit Thermometer



Adjust for 2.7315V at output of LM308

Figure 22. Centigrade Thermometer

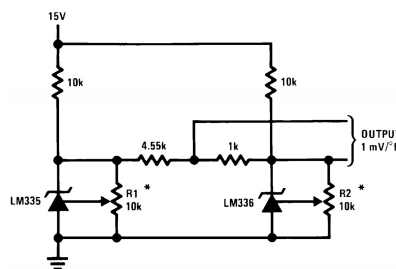

To calibrate adjust R2 for 2.554V across LM336.
Adjust R1 for correct output.

Figure 23. Fahrenheit Thermometer

System Examples (continued)

8.3.1 Thermocouple Cold Junction Compensation

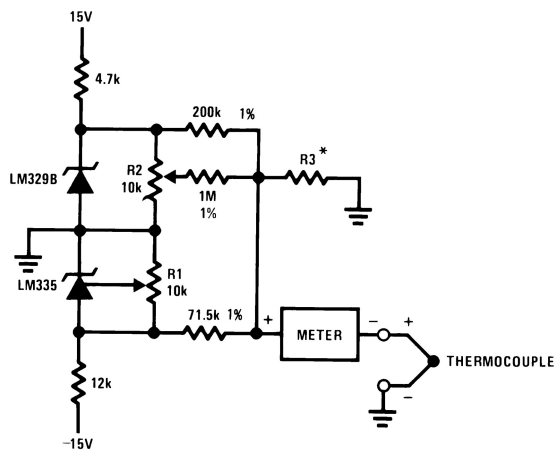

Compensation for Grounded Thermocouple
Select R3 for proper thermocouple type

Figure 24. Thermocouple Cold Junction Compensation

THERMO-COUPLE	R3 (±1%)	SEEBECK COEFFICIENT
J	377 Ω	52.3 μV/°C
T	308 Ω	42.8 μV/°C
K	293 Ω	40.8 μV/°C
S	45.8 Ω	6.4 μV/°C

Adjustments: Compensates for both sensor and resistor tolerances

1. Short LM329B
2. Adjust R1 for Seebeck Coefficient times ambient temperature (in degrees K) across R3.
3. Short LM335 and adjust R2 for voltage across R3 corresponding to thermocouple type.

J 14.32 mV K 11.17 mV
T 11.79 mV S 1.768 mV

THERMO-COUPLE	R3	R4	SEEBECK COEFFICIENT
J	1.05K	385Ω	52.3 μV/°C
T	856Ω	315Ω	42.8 μV/°C
K	816Ω	300Ω	40.8 μV/°C
S	128Ω	46.3Ω	6.4 μV/°C

Adjustments:

1. Adjust R1 for the voltage across R3 equal to the Seebeck Coefficient times ambient temperature in degrees Kelvin.
2. Adjust R2 for voltage across R4 corresponding to thermocouple.

J	14.32 mV
T	11.79 mV
K	11.17 mV
S	1.768 mV

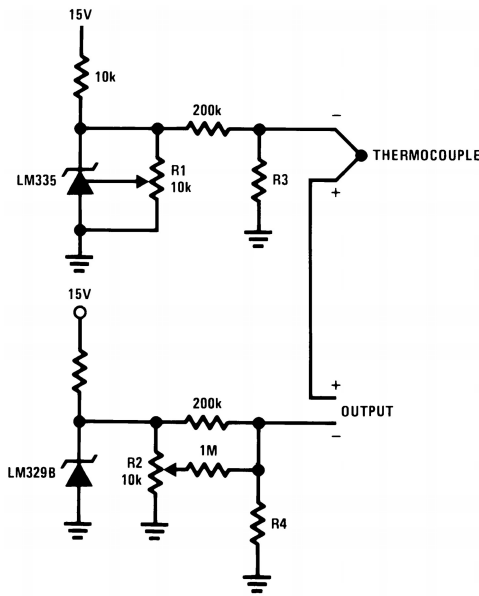

Select R3 and R4 for thermocouple type

Figure 25. Single Power Supply Cold Junction Compensation

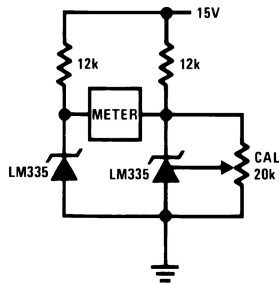
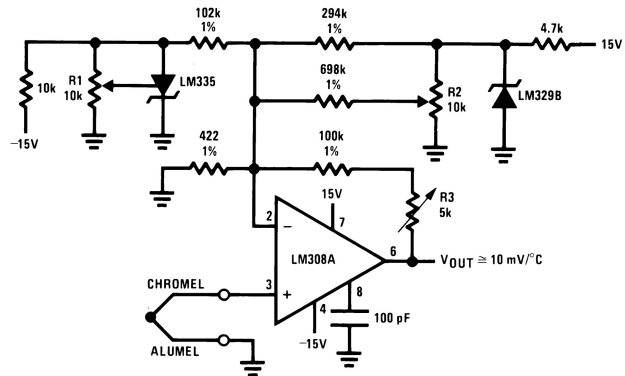

Figure 27. Differential Temperature Sensor



Terminate thermocouple reference junction in close proximity to LM335.

Adjustments:

1. Apply signal in place of thermocouple and adjust R3 for a gain of 245.7.
2. Short non-inverting input of LM308A and output of LM329B to ground.
3. Adjust R1 so that $V_{OUT} = 2.982V @ 25^{\circ}C$.
4. Remove short across LM329B and adjust R2 so that $V_{OUT} = 246 mV @ 25^{\circ}C$.
5. Remove short across thermocouple.

Figure 26. Centigrade Calibrated Thermocouple Thermometer

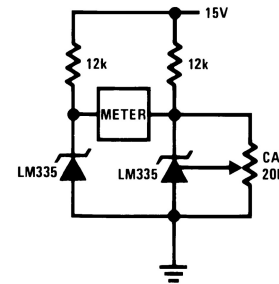
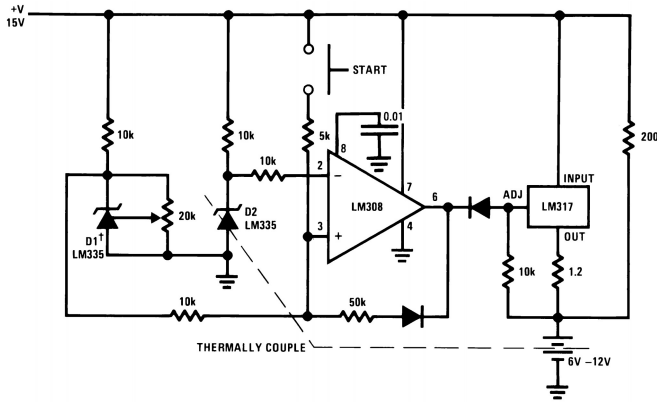
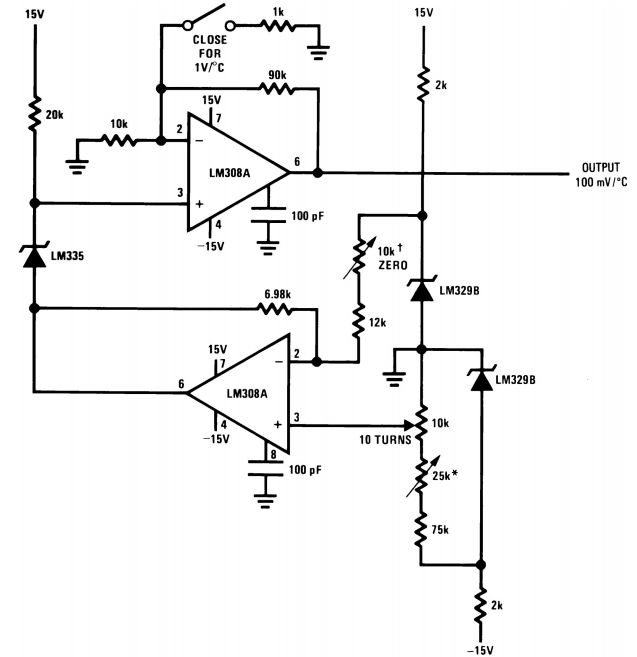

Figure 28. Differential Temperature Sensor



Adjust D1 to 50 mV greater V_Z than D2.
 Charge terminates on 5°C temperature rise.
 Couple D2 to battery.

Figure 29. Fast Charger For Nickel-Cadmium Batteries



Adjust for zero with sensor at 0°C and 10T pot set at 0°C
 Adjust for zero output with 10T pot set at 100°C and sensor at 100°C
 Output reads difference between temperature and dial setting of 10T pot

Figure 30. Variable Offset Thermometer

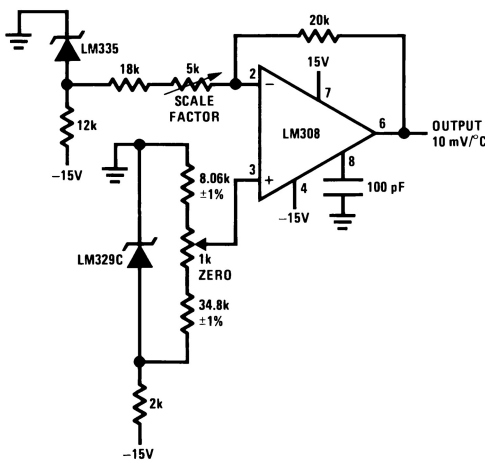
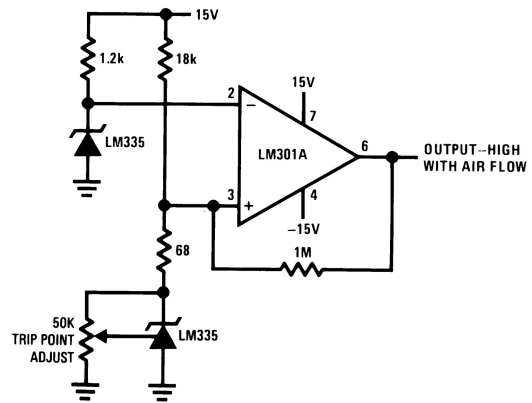

Figure 31. Ground Referred Centigrade Thermometer



*Self heating is used to detect air flow

Figure 32. Air Flow Detector

9 Power Supply Recommendations

Ensure the LM335 is biased properly with a current ranging 0.4 mA to 5 mA.

10 Layout

10.1 Layout Guidelines

The LM135 is applied easily in the same way as other integrated-circuit temperature sensors. Glue or cement the device to a surface and the temperature should be within about 0.01°C of the surface temperature.

Efficient temperature transfer assumes that the ambient air temperature is almost the same as the surface temperature where the LM135 leads are attached. If there is a great difference between the air temperature and the surface temperature, the actual temperature of the LM135 die would be at an intermediate temperature between the two temperatures. For example, the TO-92 plastic package, where the copper leads are the principal thermal path to carry heat into the device, can be greatly affected by airflow. The temperature sensed by the TO92 package could greatly depend on velocity of the airflow as well.

To lessen the affect of airflow, ensure that the wiring to the LM135 (leads and wires connected to the leads) is held at the same temperature as the surface temperature that is targeted for measurement. To insure that the temperature of the LM135 die is not affected by the air temperature, mechanically connect the LM135 leads with a bead of epoxy to the surface being measured. If air temperature is targeted for measurement ensure that the PCB surface temperature is close to the air temperature. Keep the LM135 away from offending PCB heat sources such as power regulators. One method commonly used for thermal isolation is to route a thermal well as shown in [Figure 33](#) with the smallest possible geometry traces connecting back to rest of the PCB.

10.2 Layout Example

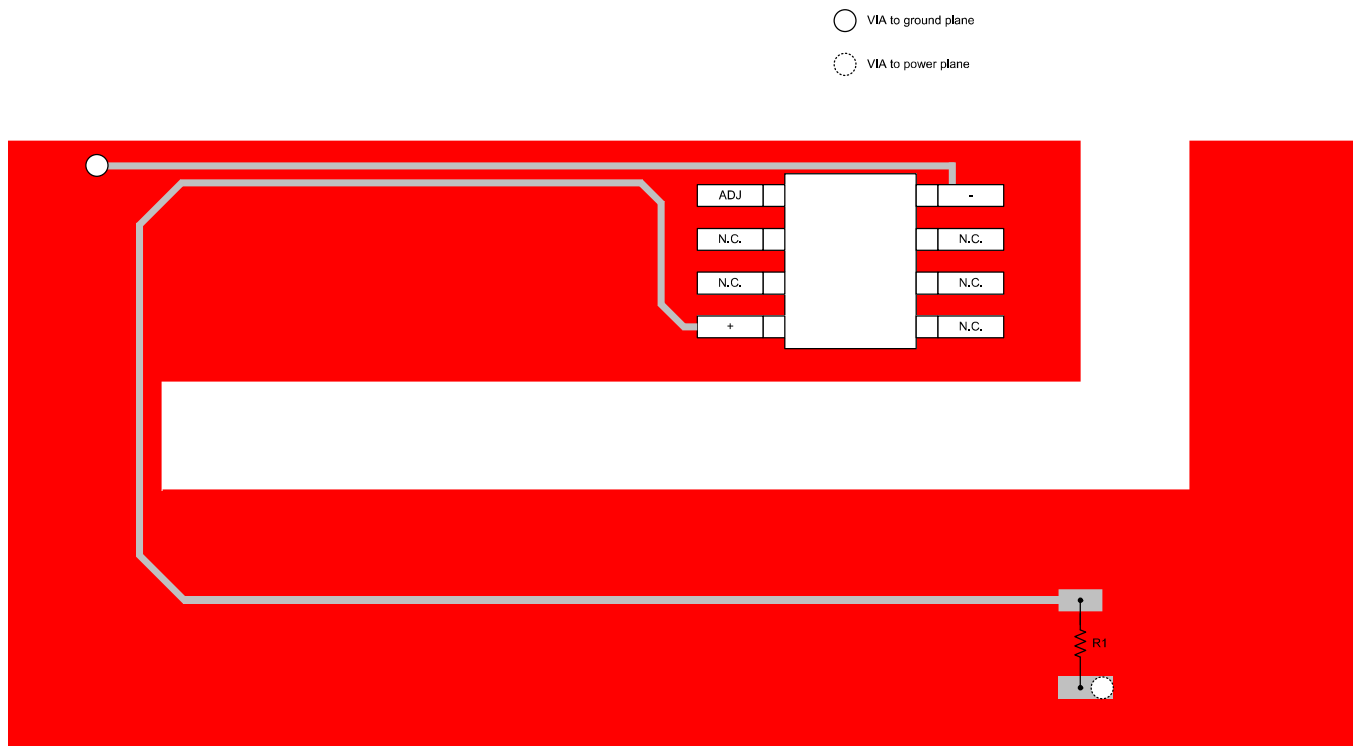

Figure 33. Layout Example

10.3 Waterproofing Sensors

Meltable inner-core, heat-shrinkable tubing, such as manufactured by Raychem, can be used to make low-cost waterproof sensors. The LM335 is inserted into the tubing about 0.5 inches from the end and the tubing heated above the melting point of the core. The unfilled 0.5-inch end melts and provides a seal over the device.

10.4 Mounting the Sensor at the End of a Cable

The main error due to a long wire is caused by the voltage drop across that wire caused by the reverse current biasing the LM135 on. Table 2 shows the wire AWG and the length of wire that would cause 1°C error.

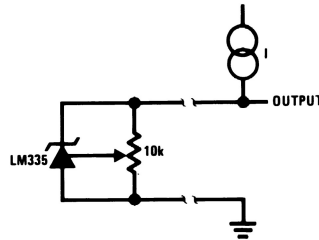

Figure 34. Cable Connected Temperature Sensor

Table 2. Wire Length for 1°C Error Due to Wire Drop

AWG	$I_R = 1 \text{ mA}$	$I_R = 0.5 \text{ mA}^{(1)}$
	FEET	FEET
14	4000	8000
16	2500	5000
18	1600	3200
20	1000	2000
22	625	1250
24	400	800

(1) For $I_R = 0.5 \text{ mA}$, the trim pot must be deleted.

11 Device and Documentation Support

11.1 Device Support

11.1.1 Device Nomenclature

Operating Output Voltage: The voltage appearing across the positive and negative terminals of the device at specified conditions of operating temperature and current.

Uncalibrated Temperature Error: The error between the operating output voltage at 10 mV/°K and case temperature at specified conditions of current and case temperature.

Calibrated Temperature Error: The error between operating output voltage and case temperature at 10 mV/°K over a temperature range at a specified operating current with the 25°C error adjusted to zero.

11.2 Related Links

The table below lists quick access links. Categories include technical documents, support and community resources, tools and software, and quick access to sample or buy.

Table 3. Related Links

PARTS	PRODUCT FOLDER	SAMPLE & BUY	TECHNICAL DOCUMENTS	TOOLS & SOFTWARE	SUPPORT & COMMUNITY
LM135	Click here	Click here	Click here	Click here	Click here
LM135A	Click here	Click here	Click here	Click here	Click here
LM235	Click here	Click here	Click here	Click here	Click here
LM235A	Click here	Click here	Click here	Click here	Click here
LM335	Click here	Click here	Click here	Click here	Click here
LM335A	Click here	Click here	Click here	Click here	Click here

11.3 Trademarks

All trademarks are the property of their respective owners.

11.4 Electrostatic Discharge Caution



These devices have limited built-in ESD protection. The leads should be shorted together or the device placed in conductive foam during storage or handling to prevent electrostatic damage to the MOS gates.

11.5 Glossary

[SLYZ022](#) — *TI Glossary*.

This glossary lists and explains terms, acronyms, and definitions.

12 Mechanical, Packaging, and Orderable Information

The following pages include mechanical, packaging, and orderable information. This information is the most current data available for the designated devices. This data is subject to change without notice and revision of this document. For browser-based versions of this data sheet, refer to the left-hand navigation.