

## LM120/LM320-N Series 3-Terminal Negative Regulators

 Check for Samples: [LM120](#), [LM320-N](#)

### FEATURES

- Preset Output Voltage Error Less than  $\pm 3\%$
- Preset Current Limit
- Internal Thermal Shutdown
- Operates with Input-Output Voltage Differential down to 1V
- Excellent Ripple Rejection
- Low Temperature Drift
- Easily Adjustable to Higher Output Voltage

### DESCRIPTION

The LM120 series are three-terminal negative regulators with a fixed output voltage of  $-5V$ ,  $-12V$ , and  $-15V$ , and up to 1.5A load current capability. Where other voltages are required, the LM137 and LM137HV series provide an output voltage range of  $-1.2V$  to  $-47V$ .

The LM120 need only one external component—a compensation capacitor at the output, making them easy to apply. Worst case specifications on output voltage deviation due to any combination of line, load or temperature variation assure satisfactory system operation.

### Typical Applications

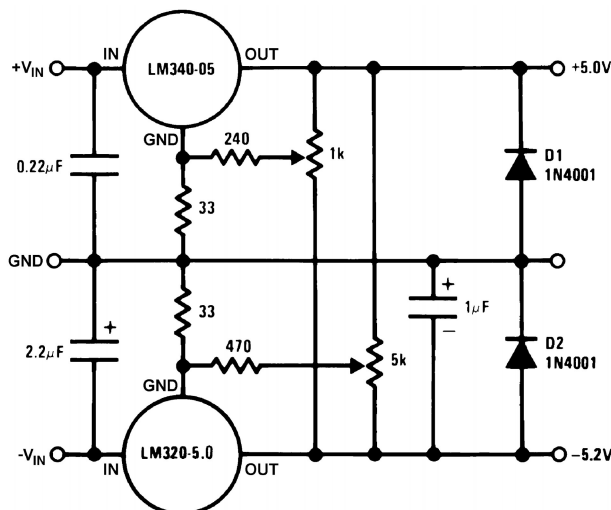

Figure 1. Dual Trimmed Supply

Exceptional effort has been made to make the LM120 Series immune to overload conditions. The regulators have current limiting which is independent of temperature, combined with thermal overload protection. Internal current limiting protects against momentary faults while thermal shutdown prevents junction temperatures from exceeding safe limits during prolonged overloads.

Although primarily intended for fixed output voltage applications, the LM120 Series may be programmed for higher output voltages with a simple resistive divider. The low quiescent drain current of the devices allows this technique to be used with good regulation.

Table 1. LM120 Series Packages and Power Capability

Device	Package	Rated Power Dissipation	Design Load Current
LM120/LM320-N	TO-3 (NDS)	20W	1.5A
	TO (NDT)	2W	0.5A
LM320-N	TO-220 (NDE)	15W	1.5A

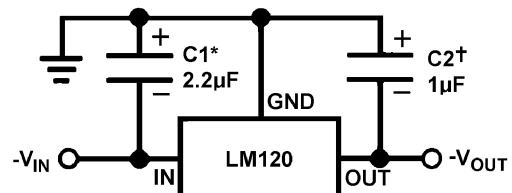

\*Required if regulator is separated from filter capacitor by more than 3 inches. For value given, capacitor must be solid tantalum. 25  $\mu F$  aluminum electrolytic may be substituted.

†Required for stability. For value given, capacitor must be solid tantalum. 25  $\mu F$  aluminum electrolytic may be substituted. Values given may be increased without limit.

For output capacitance in excess of 100  $\mu F$ , a high current diode from input to output (1N4001, etc.) will protect the regulator from momentary input shorts.

Figure 2. Fixed Regulator



Please be aware that an important notice concerning availability, standard warranty, and use in critical applications of Texas Instruments semiconductor products and disclaimers thereto appears at the end of this data sheet.

All trademarks are the property of their respective owners.



These devices have limited built-in ESD protection. The leads should be shorted together or the device placed in conductive foam during storage or handling to prevent electrostatic damage to the MOS gates.

### ABSOLUTE MAXIMUM RATINGS–5 VOLT REGULATORS <sup>(1)(2)(3)</sup>

Power Dissipation	Internally Limited
Input Voltage	–25V
Input-Output Voltage Differential	25V
Junction Temperatures	<sup>(4)</sup>
Storage Temperature Range	–65°C to +150°C
Lead Temperature	
(Soldering, 10 sec.)	300°C
Plastic	260°C

- (1) Refer to RETS120-5H drawing for LM120H-5.0 or RETS120-5K drawing for LM120-5K military specifications.  
 (2) For –5V 3 amp regulators, see LM145 data sheet.  
 (3) If Military/Aerospace specified devices are required, please contact the Texas Instruments Sales Office/Distributors for availability and specifications.  
 (4) This specification applies over  $-55^{\circ}\text{C} \leq T_J \leq +150^{\circ}\text{C}$  for the LM120 and  $0^{\circ}\text{C} \leq T_J \leq +125^{\circ}\text{C}$  for the LM320-N.

### LM120K-5.0 AND LM320K-5.0 ELECTRICAL CHARACTERISTICS <sup>(1)</sup>

Order Numbers		Metal Can Package						Units
		LM120K-5.0 (TO-3)			LM320K-5.0 (TO-3)			
Design Output Current ( $I_D$ ) Device Dissipation ( $P_D$ )		1.5A 20W						Units
Parameter	Conditions <sup>(2)</sup>	Min	Typ	Max	Min	Typ	Max	
Output Voltage	$T_J = 25^{\circ}\text{C}$ , $V_{IN} = 10\text{V}$ , $I_{LOAD} = 5\text{ mA}$	–5.1	–5	–4.9	–5.2	–5	–4.8	V
Line Regulation	$T_J = 25^{\circ}\text{C}$ , $I_{LOAD} = 5\text{ mA}$ , $V_{MIN} \leq V_{IN} \leq V_{MAX}$		10	25		10	40	mV
Input Voltage		–25		–7	–25		–7	V
Ripple Rejection	$f = 120\text{ Hz}$	54	64		54	64		dB
Load Regulation, <sup>(3)</sup>	$T_J = 25^{\circ}\text{C}$ , $V_{IN} = 10\text{V}$ , $5\text{ mA} \leq I_{LOAD} \leq I_D$		50	75		60	100	mV
Output Voltage, <sup>(2)</sup>	$-7.5\text{V} \leq V_{IN} \leq V_{MAX}$ , $5\text{ mA} \leq I_{LOAD} \leq I_D$ , $P \leq P_D$	–5.20		–4.80	–5.25		–4.75	V
Quiescent Current	$V_{MIN} \leq V_{IN} \leq V_{MAX}$		1	2		1	2	mA
Quiescent Current Change	$T_J = 25^{\circ}\text{C}$ $V_{MIN} \leq V_{IN} \leq V_{MAX}$ $5\text{ mA} \leq I_{LOAD} \leq I_D$		0.1	0.4		0.1	0.4	mA
Output Noise Voltage	$T_A = 25^{\circ}\text{C}$ , $C_L = 1\text{ }\mu\text{F}$ , $I_L = 5\text{ mA}$ , $V_{IN} = 10\text{V}$ , $10\text{ Hz} \leq f \leq 100\text{ kHz}$		150			150		$\mu\text{V}$
Long Term Stability			5	50		5	50	mV
Thermal Resistance								
Junction to Case				3			3	$^{\circ}\text{C/W}$
Junction to Ambient				35			35	$^{\circ}\text{C/W}$

- (1) For –5V 3 amp regulators, see LM145 data sheet.  
 (2) This specification applies over  $-55^{\circ}\text{C} \leq T_J \leq +150^{\circ}\text{C}$  for the LM120 and  $0^{\circ}\text{C} \leq T_J \leq +125^{\circ}\text{C}$  for the LM320-N.  
 (3) Regulation is measured at constant junction temperature. Changes in output voltage due to heating effects must be taken into account separately. To ensure constant junction temperature, low duty cycle, pulse testing is used. The LM120/LM320-N series does have low thermal feedback, improving line and load regulation. On all other tests, even though power dissipation is internally limited, electrical specifications apply only up to  $P_D$ .

**LM120H-5.0 ELECTRICAL CHARACTERISTICS<sup>(1)</sup>**

Order Numbers		Metal Can Package			Units
		LM120H-5.0 (TO)			
Design Output Current ( $I_D$ ) Device Dissipation ( $P_D$ )		0.5A 2W			
Parameter	Conditions <sup>(2)</sup>	Min	Typ	Max	
Output Voltage	$T_J = 25^\circ\text{C}$ , $V_{IN} = 10\text{V}$ , $I_{LOAD} = 5\text{ mA}$	-5.1	-5	-4.9	V
Line Regulation	$T_J = 25^\circ\text{C}$ , $I_{LOAD} = 5\text{ mA}$ , $V_{MIN} \leq V_{IN} \leq V_{MAX}$		10	25	mV
Input Voltage		-25		-7	V
Ripple Rejection	$f = 120\text{ Hz}$	54	64		dB
Load Regulation, (3)	$T_J = 25^\circ\text{C}$ , $V_{IN} = 10\text{V}$ , $5\text{ mA} \leq I_{LOAD} \leq I_D$		30	50	mV
Output Voltage, (4)	$-7.5\text{V} \leq V_{IN} \leq V_{MAX}$ , $5\text{ mA} \leq I_{LOAD} \leq I_D$ , $P \leq P_D$	-5.20		-4.80	V
Quiescent Current	$V_{MIN} \leq V_{IN} \leq V_{MAX}$		1	2	mA
Quiescent Current Change	$T_J = 25^\circ\text{C}$ $V_{MIN} \leq V_{IN} \leq V_{MAX}$ $5\text{ mA} \leq I_{LOAD} \leq I_D$		0.05 0.04	0.4 0.4	mA mA
Output Noise Voltage	$T_A = 25^\circ\text{C}$ , $C_L = 1\text{ }\mu\text{F}$ , $I_L = 5\text{ mA}$ , $V_{IN} = 10\text{V}$ , $10\text{ Hz} \leq f \leq 100\text{ kHz}$		150		$\mu\text{V}$
Long Term Stability			5		mV
Thermal Resistance Junction to Case				(5)	$^\circ\text{C/W}$
Junction to Ambient				(5)	$^\circ\text{C/W}$

(1) For -5V 3 amp regulators, see LM145 data sheet.

(2) This specification applies over  $-55^\circ\text{C} \leq T_J \leq +150^\circ\text{C}$  for the LM120 and  $0^\circ\text{C} \leq T_J \leq +125^\circ\text{C}$  for the LM320-N.

(3) Regulation is measured at constant junction temperature. Changes in output voltage due to heating effects must be taken into account separately. To ensure constant junction temperature, low duty cycle, pulse testing is used. The LM120/LM320-N series does have low thermal feedback, improving line and load regulation. On all other tests, even though power dissipation is internally limited, electrical specifications apply only up to  $P_D$ .

(4) This specification applies over  $-55^\circ\text{C} \leq T_J \leq +150^\circ\text{C}$  for the LM120 and  $0^\circ\text{C} \leq T_J \leq +125^\circ\text{C}$  for the LM320-N.

(5) Thermal resistance of typically  $85^\circ\text{C/W}$  (in 400 linear feet air flow),  $224^\circ\text{C/W}$  (in static air) junction to ambient, of typically  $21^\circ\text{C/W}$  junction to case.

**ABSOLUTE MAXIMUM RATINGS–12 VOLT REGULATORS<sup>(1)(2)</sup>**

Power Dissipation	Internally Limited
Input Voltage	-35V
Input-Output Voltage Differential	30V
Junction Temperatures	(3)
Storage Temperature Range	$-65^\circ\text{C}$ to $+150^\circ\text{C}$
Lead Temperature (Soldering, 10 sec.)	300 $^\circ\text{C}$

(1) Refer to RETS120H-12 drawing for LM120H-12 or RETS120-12K drawing for LM120K-12 military specifications.

(2) If Military/Aerospace specified devices are required, please contact the Texas Instruments Sales Office/Distributors for availability and specifications.

(3) This specification applies over  $-55^\circ\text{C} \leq T_J \leq +150^\circ\text{C}$  for the LM120 and  $0^\circ\text{C} \leq T_J \leq +125^\circ\text{C}$  for the LM320-N.

## LM120K-12 ELECTRICAL CHARACTERISTICS

Order Numbers		Metal Can Package			Units
		LM120K-12 (TO-3)			
Design Output Current ( $I_D$ )		1A			
Device Dissipation ( $P_D$ )		20W			
Parameter	Conditions <sup>(1)</sup>	Min	Typ	Max	
Output Voltage	$T_J = 25^\circ\text{C}$ , $V_{IN} = 17\text{V}$ , $I_{LOAD} = 5\text{ mA}$	-12.3	-12	-11.7	V
Line Regulation	$T_J = 25^\circ\text{C}$ , $I_{LOAD} = 5\text{ mA}$ , $V_{MIN} \leq V_{IN} \leq V_{MAX}$		4	10	mV
Input Voltage		-32		-14	V
Ripple Rejection	$f = 120\text{ Hz}$	56	80		dB
Load Regulation, (2)	$T_J = 25^\circ\text{C}$ , $V_{IN} = 17\text{V}$ , $5\text{ mA} \leq I_{LOAD} \leq I_D$		30	80	mV
Output Voltage, (3)	$14.5\text{V} \leq V_{IN} \leq V_{MAX}$ , $5\text{ mA} \leq I_{LOAD} \leq I_D$ , $P \leq P_D$	-12.5		-11.5	V
Quiescent Current	$V_{MIN} \leq V_{IN} \leq V_{MAX}$		2	4	mA
Quiescent Current Change	$T_J = 25^\circ\text{C}$ $V_{MIN} \leq V_{IN} \leq V_{MAX}$ $5\text{ mA} \leq I_{LOAD} \leq I_D$		0.1 0.1	0.4 0.4	mA mA
Output Noise Voltage	$T_A = 25^\circ\text{C}$ , $C_L = 1\ \mu\text{F}$ , $I_L = 5\text{ mA}$ , $V_{IN} = 17\text{V}$ , $10\text{ Hz} \leq f \leq 100\text{ kHz}$		400		$\mu\text{V}$
Long Term Stability			12	120	mV
Thermal Resistance					
Junction to Case				3	$^\circ\text{C/W}$
Junction to Ambient				35	$^\circ\text{C/W}$

(1) This specification applies over  $-55^\circ\text{C} \leq T_J \leq +150^\circ\text{C}$  for the LM120 and  $0^\circ\text{C} \leq T_J \leq +125^\circ\text{C}$  for the LM320-N.

(2) Regulation is measured at constant junction temperature. Changes in output voltage due to heating effects must be taken into account separately. To ensure constant junction temperature, low duty cycle, pulse testing is used. The LM120/LM320-N series does have low thermal feedback, improving line and load regulation. On all other tests, even though power dissipation is internally limited, electrical specifications apply only up to  $P_D$ .

(3) This specification applies over  $-55^\circ\text{C} \leq T_J \leq +150^\circ\text{C}$  for the LM120 and  $0^\circ\text{C} \leq T_J \leq +125^\circ\text{C}$  for the LM320-N.

## LM120H-12 ELECTRICAL CHARACTERISTICS

Order Numbers		Metal Can Package			Units
		LM120H-12 (TO)			
Design Output Current ( $I_D$ )		0.2A			
Device Dissipation ( $P_D$ )		2W			
Parameter	Conditions <sup>(1)</sup>	Min	Typ	Max	
Output Voltage	$T_J = 25^\circ\text{C}$ , $V_{IN} = 17\text{V}$ , $I_{LOAD} = 5\text{ mA}$	-12.3	-12	-11.7	V
Line Regulation	$T_J = 25^\circ\text{C}$ , $I_{LOAD} = 5\text{ mA}$ , $V_{MIN} \leq V_{IN} \leq V_{MAX}$		4	10	mV
Input Voltage		-32		-14	V
Ripple Rejection	$f = 120\text{ Hz}$	56	80		dB
Load Regulation,	$T_J = 25^\circ\text{C}$ , $V_{IN} = 17\text{V}$ ,		10	25	mV

(1) This specification applies over  $-55^\circ\text{C} \leq T_J \leq +150^\circ\text{C}$  for the LM120 and  $0^\circ\text{C} \leq T_J \leq +125^\circ\text{C}$  for the LM320-N.

**LM120H-12 ELECTRICAL CHARACTERISTICS (continued)**

Order Numbers		Metal Can Package			Units
		LM120H-12 (TO)			
Design Output Current ( $I_D$ )		0.2A			
Device Dissipation ( $P_D$ )		2W			
Parameter	Conditions <sup>(1)</sup>	Min	Typ	Max	
(2)	$5 \text{ mA} \leq I_{LOAD} \leq I_D$				
Output Voltage, (1)	$14.5\text{V} \leq V_{IN} \leq V_{MAX}$ , $5 \text{ mA} \leq I_{LOAD} \leq I_D$ , $P \leq P_D$	-12.5		-11.5	V
Quiescent Current	$V_{MIN} \leq V_{IN} \leq V_{MAX}$		2	4	mA
Quiescent Current Change	$T_J = 25^\circ\text{C}$ $V_{MIN} \leq V_{IN} \leq V_{MAX}$ $5 \text{ mA} \leq I_{LOAD} \leq I_D$		0.05 0.03	0.4 0.4	mA mA
Output Noise Voltage	$T_A = 25^\circ\text{C}$ , $C_L = 1 \mu\text{F}$ , $I_L = 5 \text{ mA}$ , $V_{IN} = 17\text{V}$ , $10 \text{ Hz} \leq f \leq 100 \text{ kHz}$		400		$\mu\text{V}$
Long Term Stability			12	120	mV
Thermal Resistance Junction to Case Junction to Ambient				(3) (3)	$^\circ\text{C/W}$ $^\circ\text{C/W}$

- (2) Regulation is measured at constant junction temperature. Changes in output voltage due to heating effects must be taken into account separately. To ensure constant junction temperature, low duty cycle, pulse testing is used. The LM120/LM320-N series does have low thermal feedback, improving line and load regulation. On all other tests, even though power dissipation is internally limited, electrical specifications apply only up to  $P_D$ .
- (3) Thermal resistance of typically  $85^\circ\text{C/W}$  (in 400 linear feet/min air flow),  $224^\circ\text{C/W}$  (in static air) junction to ambient, of typically  $21^\circ\text{C/W}$  junction to case.

**LM320T-12 ELECTRICAL CHARACTERISTICS**

Order Numbers		Power Plastic Package			Units
		LM320T-12 (TO-220)			
Design Output Current ( $I_D$ )		1A			
Device Dissipation ( $P_D$ )		15W			
Parameter	Conditions <sup>(1)</sup>	Min	Typ	Max	
Output Voltage	$T_J = 25^\circ\text{C}$ , $V_{IN} = 17\text{V}$ , $I_{LOAD} = 5 \text{ mA}$	-12.4	-12	-11.6	V
Line Regulation	$T_J = 25^\circ\text{C}$ , $I_{LOAD} = 5 \text{ mA}$ , $V_{MIN} \leq V_{IN} \leq V_{MAX}$		4	20	mV
Input Voltage		-32		-14.5	V
Ripple Rejection	$f = 120 \text{ Hz}$	56	80		dB
Load Regulation, (2)	$T_J = 25^\circ\text{C}$ , $V_{IN} = 17\text{V}$ , $5 \text{ mA} \leq I_{LOAD} \leq I_D$		30	80	mV
Output Voltage, (1)	$14.5\text{V} \leq V_{IN} \leq V_{MAX}$ , $5 \text{ mA} \leq I_{LOAD} \leq I_D$ , $P \leq P_D$	-12.6		-11.4	V
Quiescent Current	$V_{MIN} \leq V_{IN} \leq V_{MAX}$		2	4	mA
Quiescent Current Change	$T_J = 25^\circ\text{C}$ $V_{MIN} \leq V_{IN} \leq V_{MAX}$ $5 \text{ mA} \leq I_{LOAD} \leq I_D$		0.1 0.1	0.4 0.4	mA mA

- (1) This specification applies over  $-55^\circ\text{C} \leq T_J \leq +150^\circ\text{C}$  for the LM120 and  $0^\circ\text{C} \leq T_J \leq +125^\circ\text{C}$  for the LM320-N.
- (2) Regulation is measured at constant junction temperature. Changes in output voltage due to heating effects must be taken into account separately. To ensure constant junction temperature, low duty cycle, pulse testing is used. The LM120/LM320-N series does have low thermal feedback, improving line and load regulation. On all other tests, even though power dissipation is internally limited, electrical specifications apply only up to  $P_D$ .

**LM320T-12 ELECTRICAL CHARACTERISTICS (continued)**

Order Numbers		Power Plastic Package			Units
		LM320T-12 (TO-220)			
Design Output Current ( $I_D$ )		1A			
Device Dissipation ( $P_D$ )		15W			
Parameter	Conditions <sup>(1)</sup>	Min	Typ	Max	
Output Noise Voltage	$T_A = 25^\circ\text{C}$ , $C_L = 1 \mu\text{F}$ , $I_L = 5 \text{ mA}$ , $V_{IN} = 17\text{V}$ , $10 \text{ Hz} \leq f \leq 100 \text{ kHz}$		400		$\mu\text{V}$
Long Term Stability			24		mV
Thermal Resistance Junction to Case			4		$^\circ\text{C/W}$
Junction to Ambient			50		$^\circ\text{C/W}$

**ABSOLUTE MAXIMUM RATINGS–15 VOLT REGULATORS <sup>(1)(2)</sup>**

Power Dissipation	Internally Limited
Input Voltage	
LM120/LM320-N	-40V
LM320T	-35V
Input-Output Voltage Differential	30V
Junction Temperatures	<sup>(3)</sup>
Storage Temperature Range	-65 $^\circ\text{C}$ to +150 $^\circ\text{C}$
Lead Temperature (Soldering, 10 sec.)	300 $^\circ\text{C}$

- (1) Refer to RETS120-15H drawing for LM120H-15 or RETS120-15K drawing for LM120K-15 military specifications.  
(2) If Military/Aerospace specified devices are required, please contact the Texas Instruments Sales Office/Distributors for availability and specifications.  
(3) This specification applies over  $-55^\circ\text{C} \leq T_J \leq +150^\circ\text{C}$  for the LM120 and  $0^\circ\text{C} \leq T_J \leq +125^\circ\text{C}$  for the LM320-N.

**LM120K-15 AND LM320K-15 ELECTRICAL CHARACTERISTICS**

Order Numbers		Metal Can Package						Units
		LM120K-15 (TO-3)			LM320K-15 (TO-3)			
Design Output Current ( $I_D$ )		1A						
Device Dissipation ( $P_D$ )		20W						
Parameter	Conditions <sup>(1)</sup>	Min	Typ	Max	Min	Typ	Max	
Output Voltage	$T_J = 25^\circ\text{C}$ , $V_{IN} = 20\text{V}$ , $I_{LOAD} = 5 \text{ mA}$	-15.3	-15	-14.7	-15.4	-15	-14.6	V
Line Regulation	$T_J = 25^\circ\text{C}$ , $I_{LOAD} = 5 \text{ mA}$ , $V_{MIN} \leq V_{IN} \leq V_{MAX}$		5	10		5	20	mV
Input Voltage		-35		-17	-35		-17	V
Ripple Rejection	$f = 120 \text{ Hz}$	56	80		56	80		dB
Load Regulation, <sup>(2)</sup>	$T_J = 25^\circ\text{C}$ , $V_{IN} = 20\text{V}$ , $5 \text{ mA} \leq I_{LOAD} \leq I_D$		30	80		30	80	mV
Output Voltage, <sup>(1)</sup>	$17.5\text{V} \leq V_{IN} \leq V_{MAX}$ , $5 \text{ mA} \leq I_{LOAD} \leq I_D$ , $P \leq P_D$	-15.5		-14.5	-15.6		-14.4	V
Quiescent Current	$V_{MIN} \leq V_{IN} \leq V_{MAX}$		2	4		2	4	mA

- (1) This specification applies over  $-55^\circ\text{C} \leq T_J \leq +150^\circ\text{C}$  for the LM120 and  $0^\circ\text{C} \leq T_J \leq +125^\circ\text{C}$  for the LM320-N.  
(2) Regulation is measured at constant junction temperature. Changes in output voltage due to heating effects must be taken into account separately. To ensure constant junction temperature, low duty cycle, pulse testing is used. The LM120/LM320-N series does have low thermal feedback, improving line and load regulation. On all other tests, even though power dissipation is internally limited, electrical specifications apply only up to  $P_D$ .

**LM120K-15 AND LM320K-15 ELECTRICAL CHARACTERISTICS (continued)**

Order Numbers		Metal Can Package						Units
		LM120K-15 (TO-3)			LM320K-15 (TO-3)			
Design Output Current ( $I_D$ )		1A						
Device Dissipation ( $P_D$ )		20W						
Parameter	Conditions <sup>(1)</sup>	Min	Typ	Max	Min	Typ	Max	
Quiescent Current Change	$T_J = 25^\circ\text{C}$							
	$V_{\text{MIN}} \leq V_{\text{IN}} \leq V_{\text{MAX}}$ $5 \text{ mA} \leq I_{\text{LOAD}} \leq I_D$		0.1	0.4		0.1	0.4	
Output Noise Voltage	$T_A = 25^\circ\text{C}$ , $C_L = 1 \mu\text{F}$ , $I_L = 5 \text{ mA}$ , $V_{\text{IN}} = 20\text{V}$ , $10 \text{ Hz} \leq f \leq 100 \text{ kHz}$		400			400		
Long Term Stability			15	150		15	150	
Thermal Resistance	Junction to Case			3			3	
	Junction to Ambient			35			35	

**LM120H-15 ELECTRICAL CHARACTERISTICS**

Order Numbers		Metal Can Package			Units
		LM120H-15 (TO)			
Design Output Current ( $I_D$ )		0.2A			
Device Dissipation ( $P_D$ )		2W			
Parameter	Conditions <sup>(1)</sup>	Min	Typ	Max	
Output Voltage	$T_J = 25^\circ\text{C}$ , $V_{\text{IN}} = 20\text{V}$ , $I_{\text{LOAD}} = 5 \text{ mA}$	-15.3	-15	-14.7	
Line Regulation	$T_J = 25^\circ\text{C}$ , $I_{\text{LOAD}} = 5 \text{ mA}$ , $V_{\text{MIN}} \leq V_{\text{IN}} \leq V_{\text{MAX}}$		5	10	
Input Voltage		-35		-17	
Ripple Rejection	$f = 120 \text{ Hz}$	56	80		
Load Regulation, <sup>(2)</sup>	$T_J = 25^\circ\text{C}$ , $V_{\text{IN}} = 20\text{V}$ , $5 \text{ mA} \leq I_{\text{LOAD}} \leq I_D$		10	25	
Output Voltage, <sup>(1)</sup>	$17.5\text{V} \leq V_{\text{IN}} \leq V_{\text{MAX}}$ , $5 \text{ mA} \leq I_{\text{LOAD}} \leq I_D$ , $P \leq P_D$	-15.5		-14.5	
Quiescent Current	$V_{\text{MIN}} \leq V_{\text{IN}} \leq V_{\text{MAX}}$		2	4	
Quiescent Current Change	$T_J = 25^\circ\text{C}$				
	$V_{\text{MIN}} \leq V_{\text{IN}} \leq V_{\text{MAX}}$ $5 \text{ mA} \leq I_{\text{LOAD}} \leq I_D$		0.05 0.03	0.4 0.4	
Output Noise Voltage	$T_A = 25^\circ\text{C}$ , $C_L = 1 \mu\text{F}$ , $I_L = 5 \text{ mA}$ , $V_{\text{IN}} = 20\text{V}$ , $10 \text{ Hz} \leq f \leq 100 \text{ kHz}$		400		
Long Term Stability			15	150	
Thermal Resistance	Junction to Case			(3)	
	Junction to Ambient			(3)	

(1) This specification applies over  $-55^\circ\text{C} \leq T_J \leq +150^\circ\text{C}$  for the LM120 and  $0^\circ\text{C} \leq T_J \leq +125^\circ\text{C}$  for the LM320-N.

(2) Regulation is measured at constant junction temperature. Changes in output voltage due to heating effects must be taken into account separately. To ensure constant junction temperature, low duty cycle, pulse testing is used. The LM120/LM320-N series does have low thermal feedback, improving line and load regulation. On all other tests, even though power dissipation is internally limited, electrical specifications apply only up to  $P_D$ .

(3) Thermal resistance of typically  $85^\circ\text{C/W}$  (in 400 linear feet/min air flow),  $224^\circ\text{C/W}$  (in static air) junction to ambient, of typically  $21^\circ\text{C/W}$  junction to case.

**LM320T-15 ELECTRICAL CHARACTERISTICS**

Order Numbers		Power Plastic Package			Units
		LM320T-15 (TO-220)			
Design Output Current ( $I_D$ )		1A			
Device Dissipation ( $P_D$ )		15W			
Parameter	Conditions <sup>(1)</sup>	Min	Typ	Max	
Output Voltage	$T_J = 25^\circ\text{C}$ , $V_{IN} = 20\text{V}$ , $I_{LOAD} = 5\text{ mA}$	-15.5	-15	-14.5	V
Line Regulation	$T_J = 25^\circ\text{C}$ , $I_{LOAD} = 5\text{ mA}$ , $V_{MIN} \leq V_{IN} \leq V_{MAX}$		5	20	mV
Input Voltage		-35		-17.5	V
Ripple Rejection	$f = 120\text{ Hz}$	56	80		dB
Load Regulation, <sup>(2)</sup>	$T_J = 25^\circ\text{C}$ , $V_{IN} = 20\text{V}$ , $5\text{ mA} \leq I_{LOAD} \leq I_D$		30	80	mV
Output Voltage, <sup>(1)</sup>	$17.5\text{V} \leq V_{IN} \leq V_{MAX}$ , $5\text{ mA} \leq I_{LOAD} \leq I_D$ , $P \leq P_D$	-15.7		-14.3	V
Quiescent Current	$V_{MIN} \leq V_{IN} \leq V_{MAX}$		2	4	mA
Quiescent Current Change	$T_J = 25^\circ\text{C}$ $V_{MIN} \leq V_{IN} \leq V_{MAX}$ $5\text{ mA} \leq I_{LOAD} \leq I_D$		0.1 0.1	0.4 0.4	mA mA
Output Noise Voltage	$T_A = 25^\circ\text{C}$ , $C_L = 1\ \mu\text{F}$ , $I_L = 5\text{ mA}$ , $V_{IN} = 20\text{V}$ , $10\text{ Hz} \leq f \leq 100\text{ kHz}$		400		$\mu\text{V}$
Long Term Stability			30		mV
Thermal Resistance					
Junction to Case			4		$^\circ\text{C/W}$
Junction to Ambient			50		$^\circ\text{C/W}$

(1) This specification applies over  $-55^\circ\text{C} \leq T_J \leq +150^\circ\text{C}$  for the LM120 and  $0^\circ\text{C} \leq T_J \leq +125^\circ\text{C}$  for the LM320-N.

(2) Regulation is measured at constant junction temperature. Changes in output voltage due to heating effects must be taken into account separately. To ensure constant junction temperature, low duty cycle, pulse testing is used. The LM120/LM320-N series does have low thermal feedback, improving line and load regulation. On all other tests, even though power dissipation is internally limited, electrical specifications apply only up to  $P_D$ .



TYPICAL PERFORMANCE CHARACTERISTICS

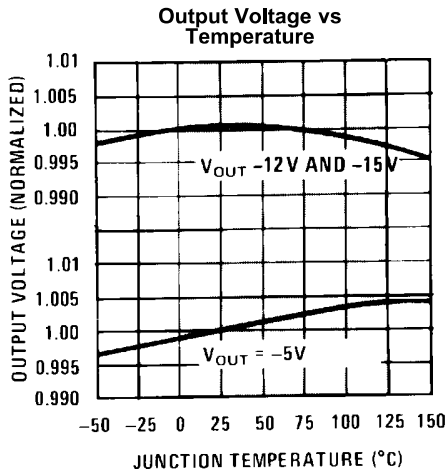

Figure 3.

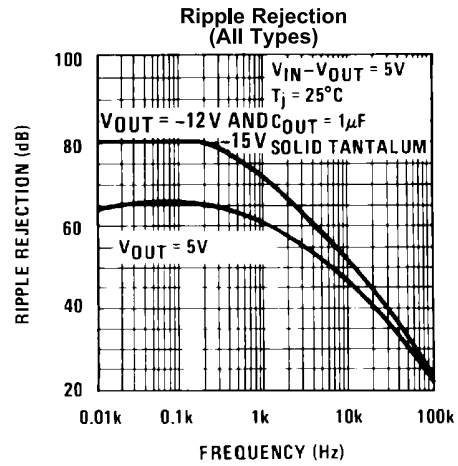

Figure 4.

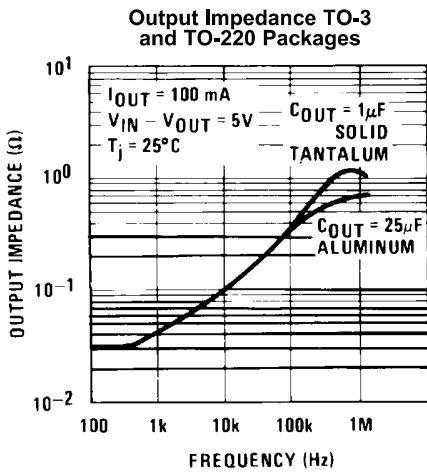

Figure 5.

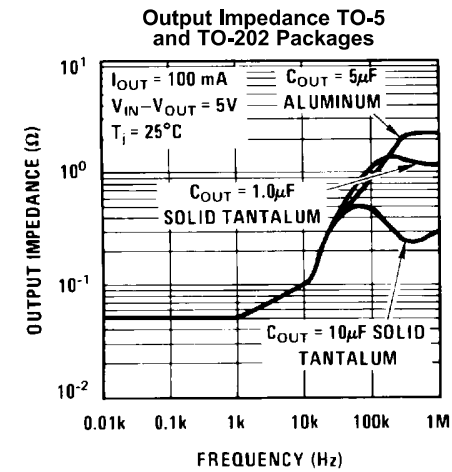

Figure 6.

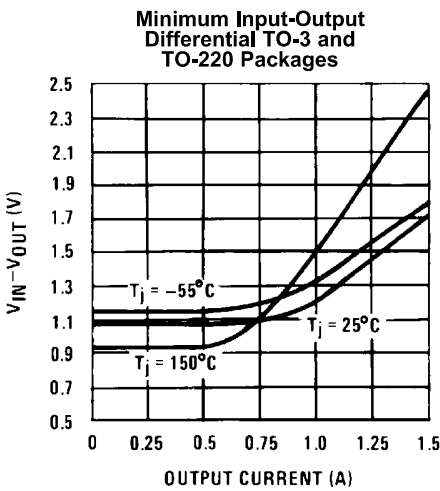

Figure 7.

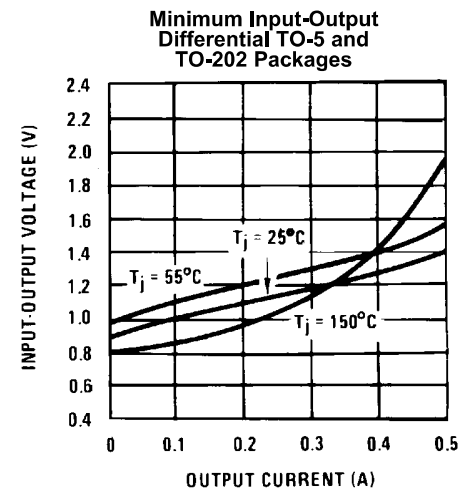

Figure 8.

**TYPICAL PERFORMANCE CHARACTERISTICS (continued)**

**Quiescent Current vs Input Voltage**

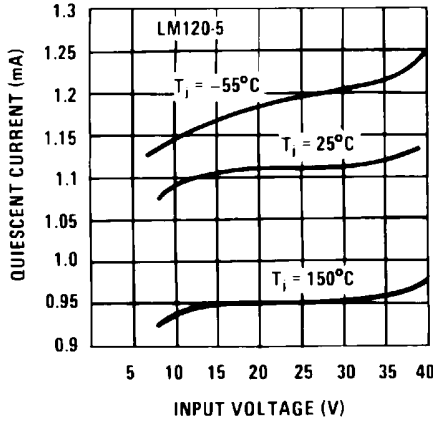

Figure 9.

**Quiescent Current vs Load Current**

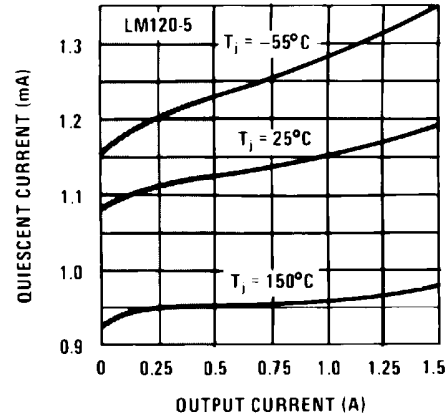

Figure 10.

**Maximum Average Power Dissipation (TO-3)**

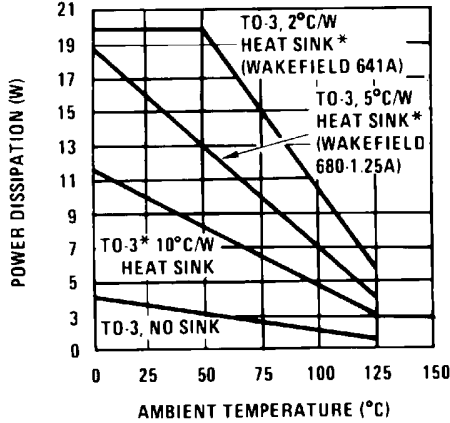

Figure 11.

**Maximum Average Power Dissipation (TO-5)**

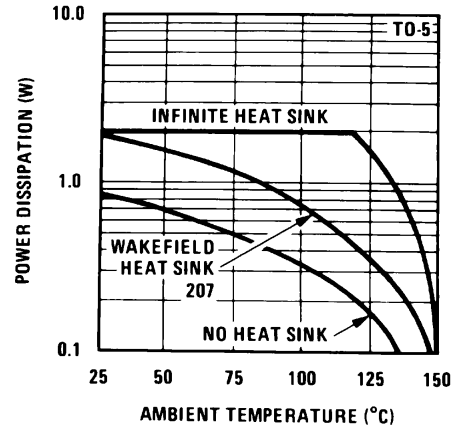

Figure 12.

\*These curves for LM120. Derate 25°C further for LM320-N.

**Maximum Average Power Dissipation (TO-202)**

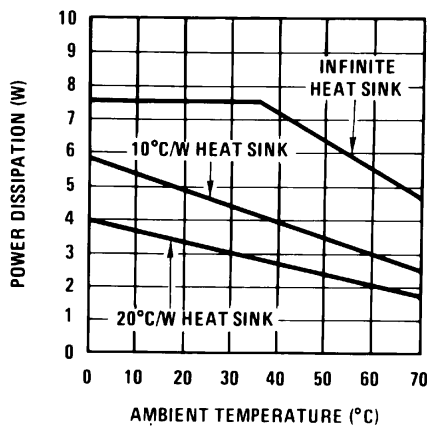

Figure 13.

**Maximum Average Power Dissipation (TO-220)**

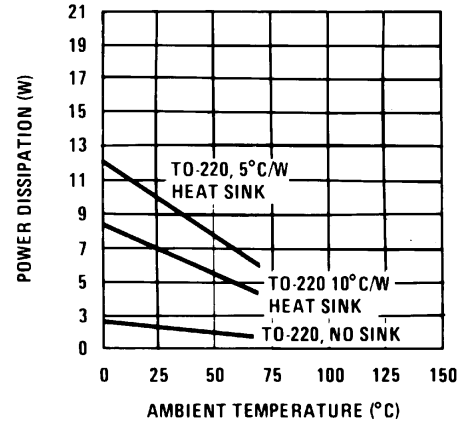
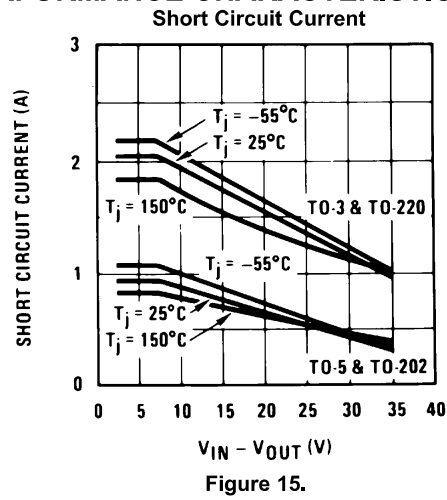
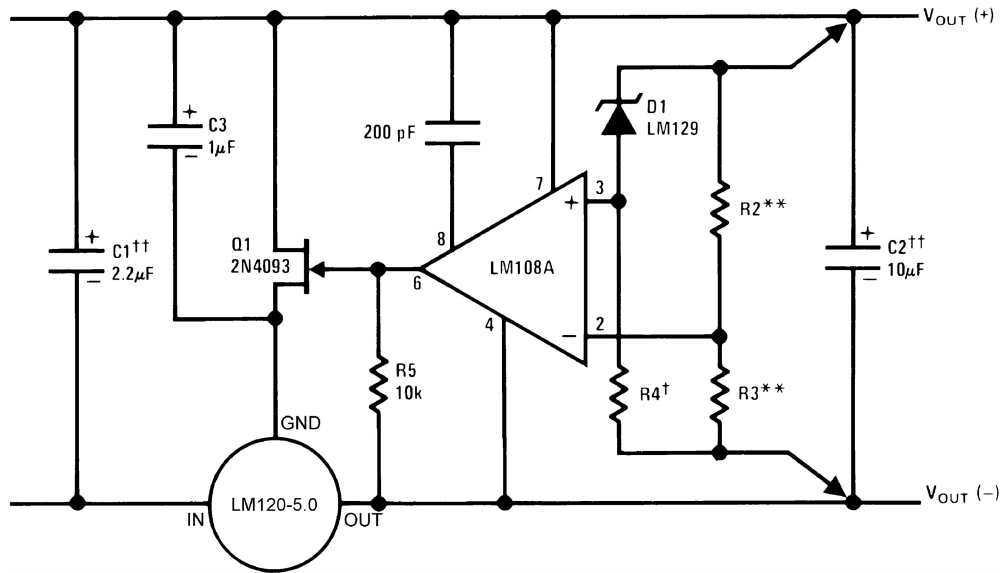

Figure 14.

TYPICAL PERFORMANCE CHARACTERISTICS (continued)



TYPICAL APPLICATIONS



Lead and line regulation — 0.01% temperature stability — 0.2%

†Determines Zener current.

††Solid tantalum.

An LM120-12 or LM120-15 may be used to permit higher input voltages, but the regulated output voltage must be at least -15V when using the LM120-12 and -18V for the LM120-15.

\*\*Select resistors to set output voltage. 2 ppm/°C tracking suggested.

Figure 16. High Stability 1 Amp Regulator

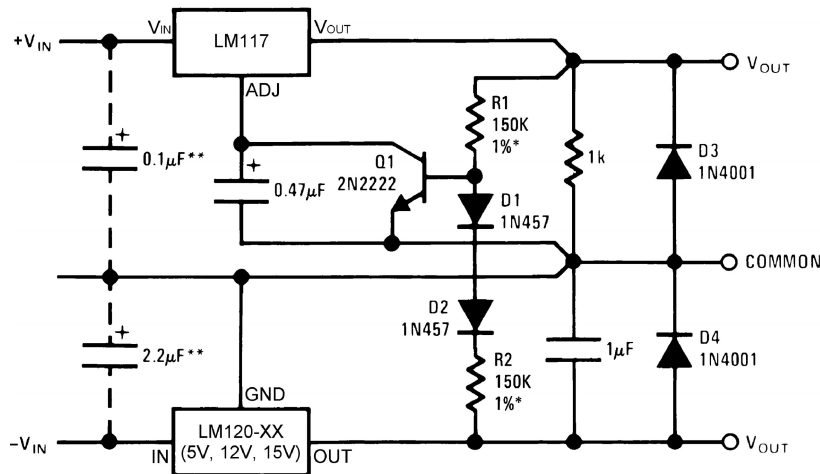

\*Resistor tolerance of R1 and R2 determine matching of (+) and (-) inputs.

\*\*Necessary only if raw supply capacitors are more than 3" from regulators

An LM3086N array may substitute for Q1, D1 and D2 for better stability and tracking. In the array diode transistors Q5 and Q4 (in parallel) make up D2; similarly, Q1 and Q2 become D1 and Q3 replaces the 2N2222.

Figure 17. Wide Range Tracking Regulator

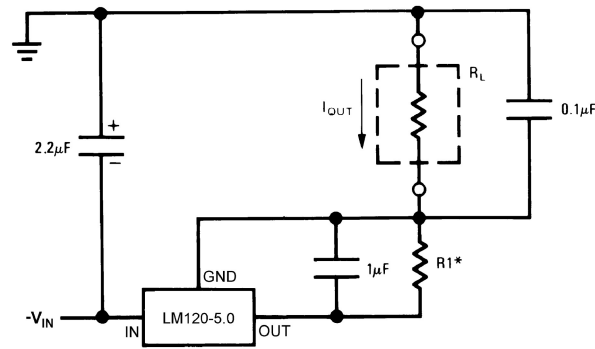

$$I_{OUT} = 1 \text{ mA} + \frac{5.0\text{V}}{R_1}$$

Figure 18. Current Source

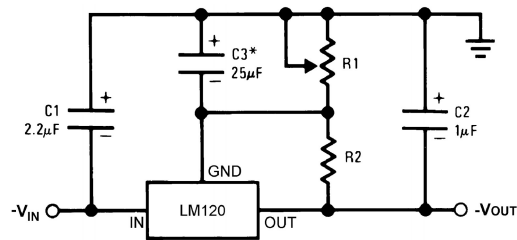

SELECT R2 AS FOLLOWS:

LM120-5      300Ω

LM120-12    750Ω

LM120-15    1k

$$V_{OUT} = V_{SET} \frac{R_1 + R_2}{R_2}$$

\*C3 optional. Improves transient response and ripple rejection.

Figure 19. Variable Output Current Source

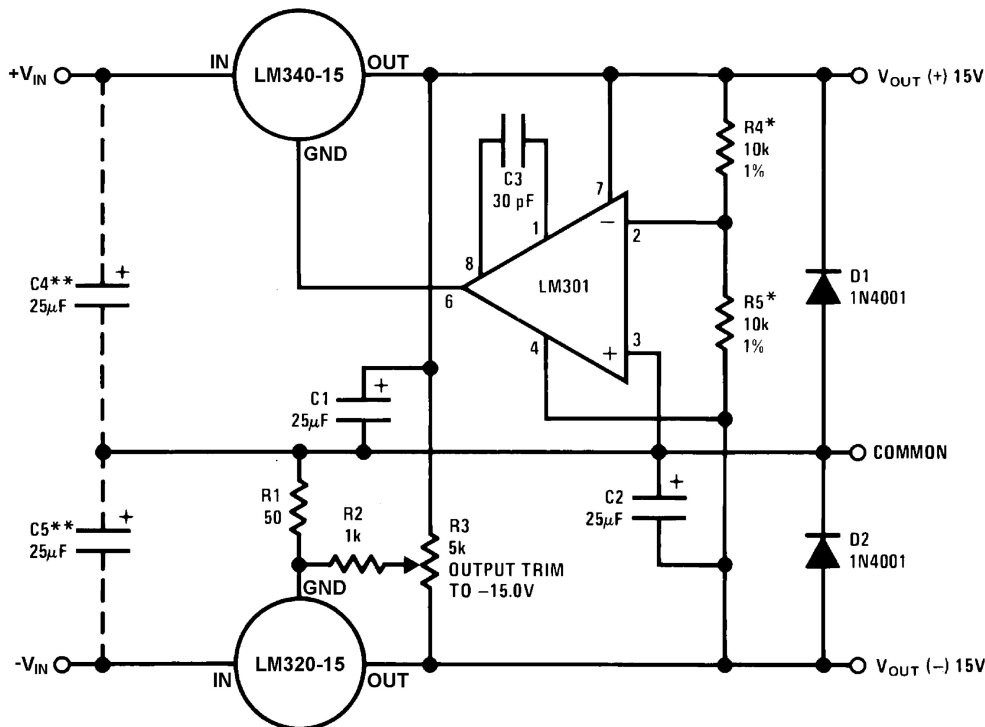

See [Performance \(Typical\)](#)

\*Resistor tolerance of R4 and R5 determine matching of (+) and (-) outputs.

\*\*Necessary only if raw supply filter capacitors are more than 2 inches from regulators.

**Figure 20. ±15V, 1 Amp Tracking Regulators**

**Performance (Typical)**

Load Regulation at $\Delta I_L = 1A$	10 mV	1 mV
Output Ripple, $C_{IN} = 3000 \mu F$ , $I_L = 1A$	100 $\mu V_{rms}$	100 $\mu V_{rms}$
Temperature Stability	+50 mV	+50 mV
Output Noise 10 Hz $\leq f \leq$ 10 kHz	150 $\mu V_{rms}$	150 $\mu V_{rms}$

**Light Controllers Using Silicon Photo Cells**

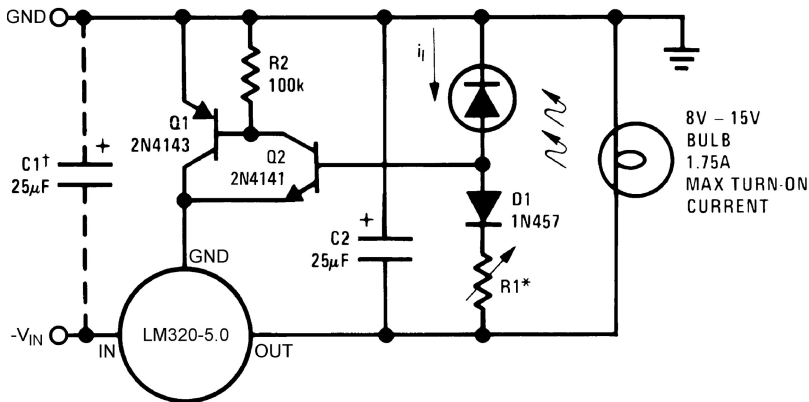

\*Lamp brightness increases until  $i_l = 5V/R1$  ( $i_l$  can be set as low as 1  $\mu A$ ).

†Necessary only if raw supply filter capacitor is more than 2 inches from LM320MP.

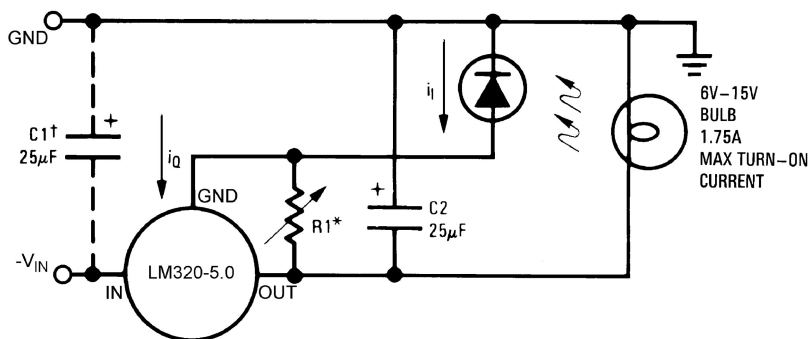

\*Lamp brightness increases until  $i_I = i_Q (1 \text{ mA}) + 5V/R1$ .

†Necessary only if raw supply filter capacitor is more than 2 inches from LM320-N.

### Connection Diagram

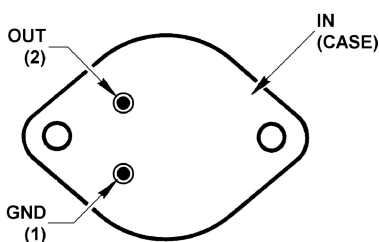

Figure 21. Steel Metal Can Package TO-3 (NDS) (Bottom View)

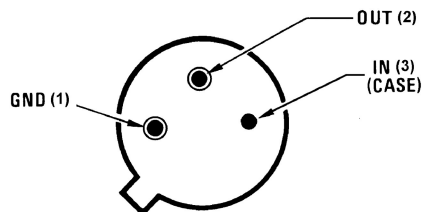

Figure 22. Metal Can Package TO (NDT) (Bottom View)

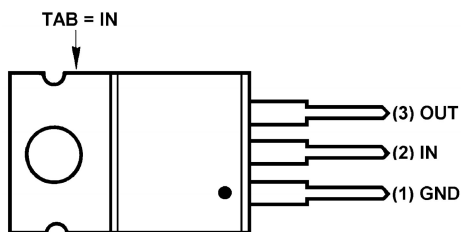

Figure 23. Power Package TO-220 (NDE) (Front View)

Schematic Diagrams

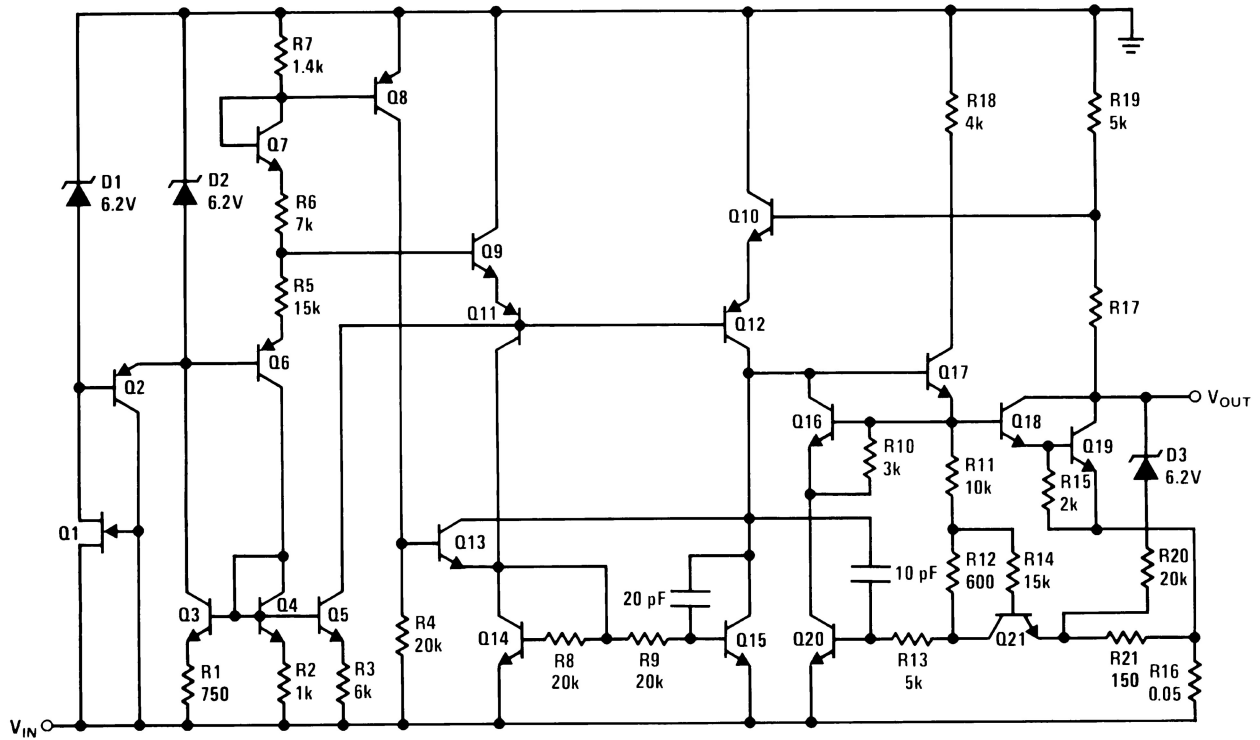

Figure 24. -5V

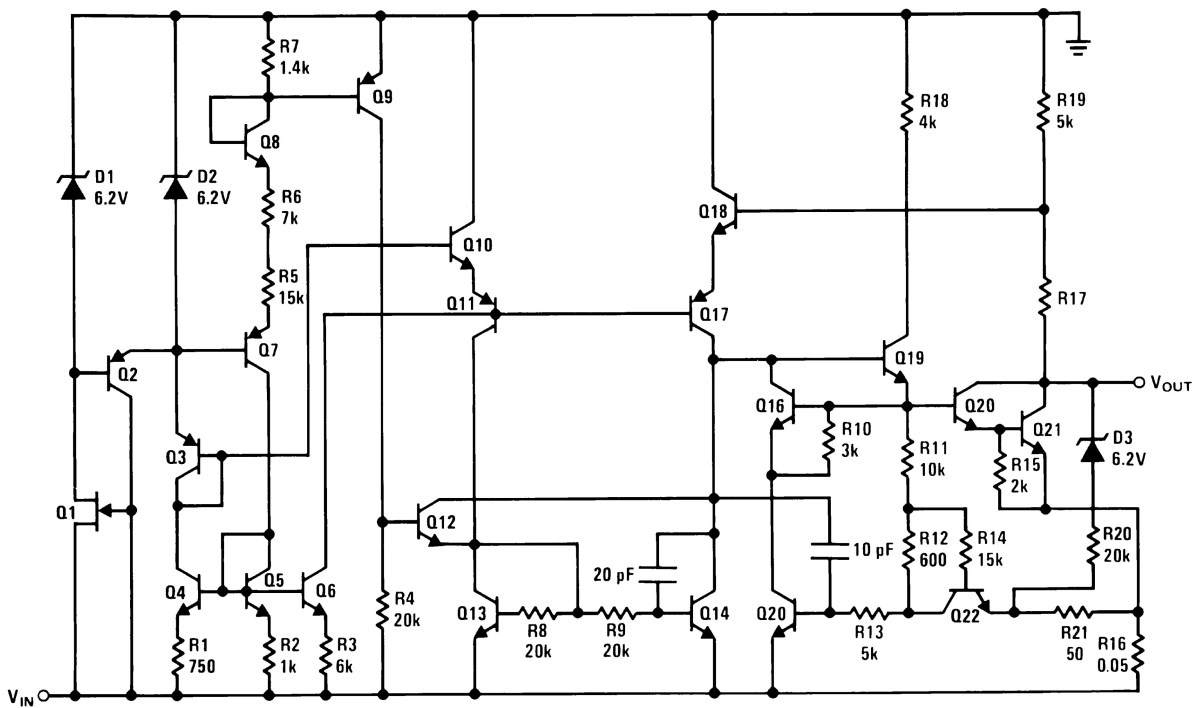

Figure 25. -12V and -15V



---

**REVISION HISTORY**

<b>Changes from Revision B (April 2013) to Revision C</b>	<b>Page</b>
• Changed layout of National Data Sheet to TI format .....	<a href="#">16</a>

---